

Unitite <sup>U</sup>



# IMPLANTAT

Discover **IMPLANTAT**, the educational habitat of S.I.N.  
An online teaching platform created to make more professionals  
accelerate their career and increase their success.

Access  
**IMPLANTAT.GLOBAL**  
or scan the QR Code and begin  
your journey of knowledge now!



EDUCATION POWERED BY S.I.N.



# Unitite



## Scientific Evidence

- › Research and development of products in partnership with renowned universities and institutes around the world as:  
Aarhus University - Denmark,  
Chalmers University - Sweden,  
KU Lueven - Belgium,  
Malmö University - Sweden,  
UNESP - Brazil,  
USP - Brazil,  
UFU - Brazil,  
SLmandic - Brazil.

## Production Excellence

- › Large investments in technological updating of our manufacturing facilities over the past three years in state-of-the-art equipment.
- › Annual production of over 5 million items.



Get to know our Smile Factory.  
Scan the QR code with  
your cell phone camera and  
take a 360° tour of S.I.N.

## Global Presence

- › One of the most important implant companies worldwide.
- › Wide international presence.

## Guaranteed Quality and Certifications

- › Rigorous quality control of process, from the arrival of the raw material to the delivery of the final product, proven through national and international certifications.



# Unitite



DOWNLOAD THE S.I.N. APP  
AND SEE IN AUGMENTED REALITY  
Place the cellphone camera over the image

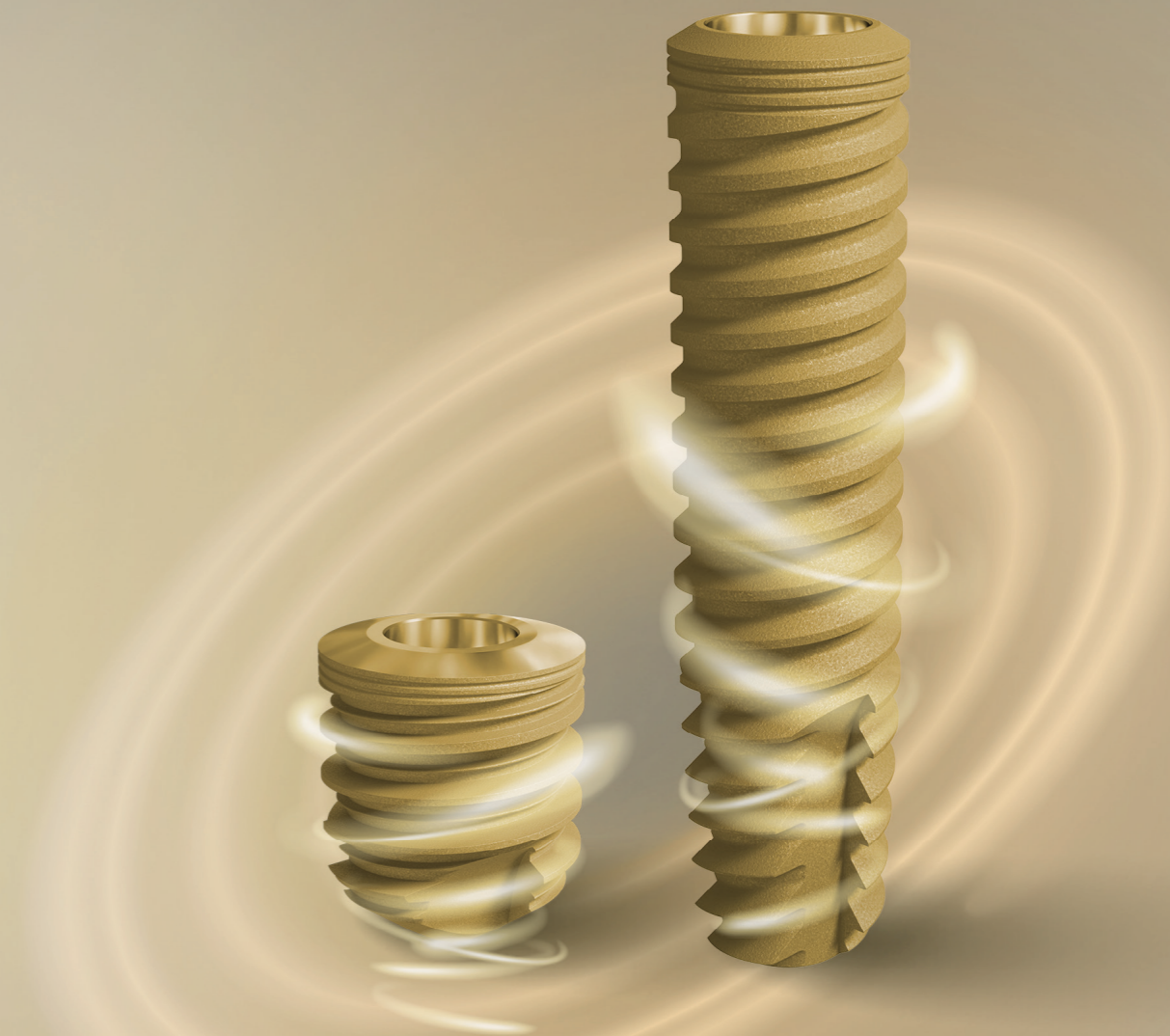

# UNITITE®

## REDEFINING CONCEPTS IN IMPLANTOLOGY

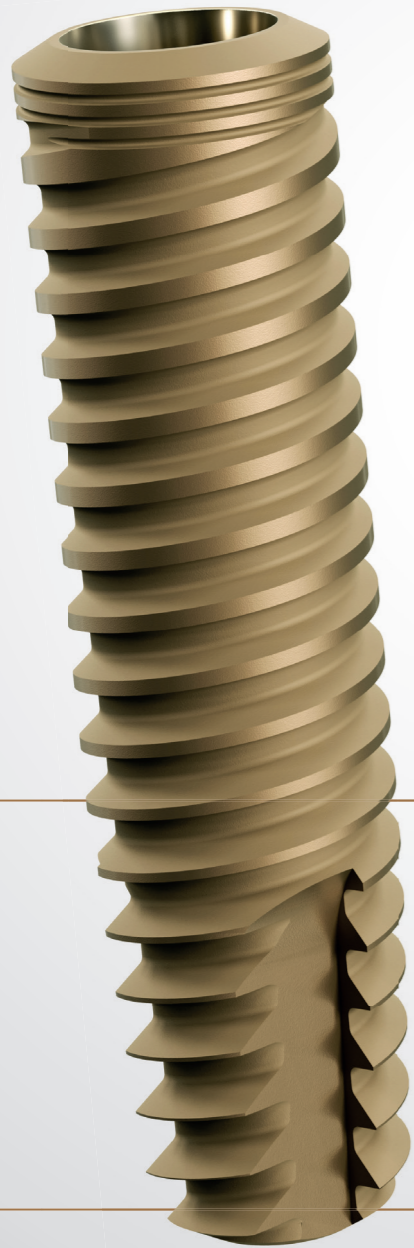

UNITITE® SLIM

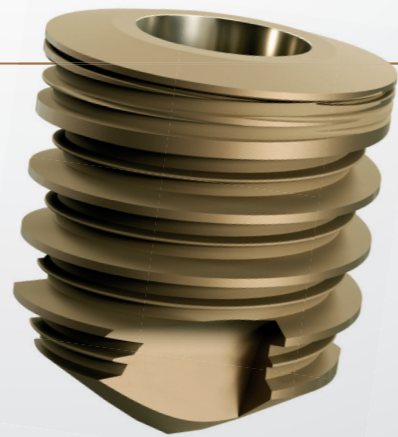

UNITITE® COMPACT

From the synergy between the exclusive **macrogeometry** and the most advanced **surface nanoactivation** emerges the **UNITITE®**, an implant line that has revolutionized the world market due to its originality, innovation, and high performance.

**EXPLORE THE BEST IMPLANT OF THE PRESENT.**

- Exclusive **HAnano®** surface: developed at Chalmers University, in Sweden, HAnano® was evaluated by more than 50 preclinical and clinical studies, which verify a faster osseointegration, besides promoting a superior bone quality.

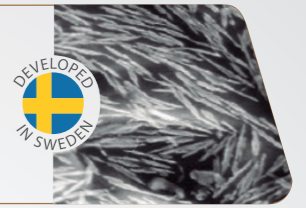

- Healing Chambers: only the external threads touches the bone tissue, while the internal threads are kept apart, promoting a very high quality hybrid healing.

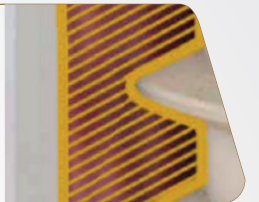

- Faster with more bone: the high hydrophilicity, which is generated by an ultrafine and homogeneous layer of hydroxyapatite, increases the activity of the proteins involved in the process of osseointegration.

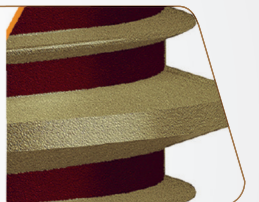

- Distinctive hybrid macrogeometry: accuracy of the drilling system and the design of the external threads give high stability, and minimize the compression of the healing bone tissue.



- Scientific evidence: more than 10 years of research and development with the renowned scientists in at leading universities worldwide.



## COMPLETE SOLUTIONS

Unitite® brings you what is the most modern in the world of implantology. Using Unitite® Slim, and Unitite® Compact your surgical planning has more possibilities for innovative and high-performance solutions.

*One concept,  
several possibilities.*

# HA<sup>nano</sup> Surface

Hydroxyapatite (HA), which is the main mineral present in the natural bone structure, when applied on the surface of nanostructured titanium implants, forms a homogeneous and stable coating functioning as a scar catalyst that speeds up osseointegration when compared to conventional surfaces. From 2005 on, HAnano® surfaces have been developed by researchers from leading universities in Gothenburg (Sweden). Scientists from several countries have tested and approved its effectiveness, the results of which have been published in dozens of articles in world-renowned scientific journals. The HAnano® coating is formed by hydroxyapatite nanocrystals, with size and shape similar to those of human bone, sintered on a microrough titanium measuring 20 nm thick that promotes a change on surface energy, increasing the hydrophilicity

and providing substrate that stimulates a greater osteoblasts multiplication. The HAnano® present on the surface of the Unitite® and Strong SW Plus implants has shown an improvement in scar response in molecular tests of signal transduction, where the proteins involved in the scar process recorded a substantial increase in concentration, presenting the coating positive effect on the interaction with the pre-osteoblastic cells. Likewise, there was an increase in the concentration of important osteogenic markers, such as alkaline phosphatase and osteocalcin, in a clear signaling of the mineralization process acceleration. Among the most relevant aspects, with the greatest clinical significance, is the bone mechanical quality which is formed around this highly hydrophilic Unitite® and Strong SW Plus surface, which derives from the resulting ionic potential of the HAnano®.

The image below shows the Unitite® surface at an increase of 5.000x / 10,000x / 100,000x respectively. The moderately rough Ti surface with the PLUS of a nano-layer of Hydroxyapatite.

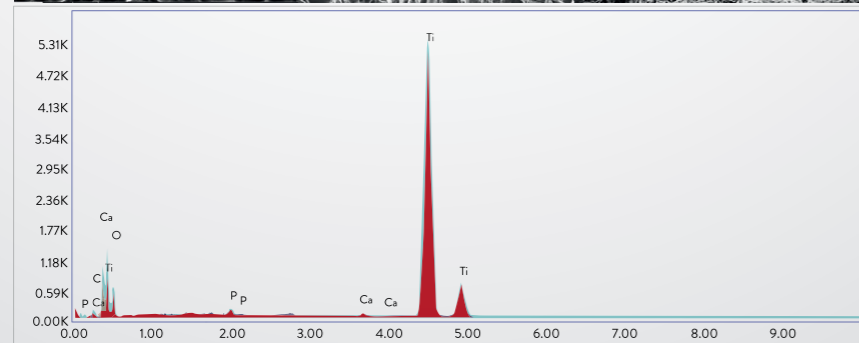
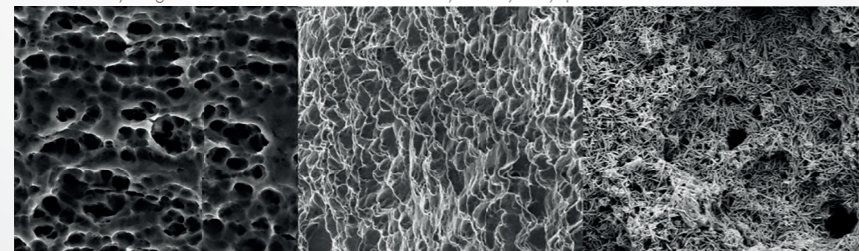

The chart and table above corresponds to an EDS analysis on the Unitite® surface, bringing the purity and stability of the implant surface closer.

## SCIENTIFIC PUBLICATIONS

The positive and superior results of HAnano® have been evaluated and proven by numerous scientific studies in several recognized universities and research institutions worldwide. You can check some of them on the QR Codes below:

### NANO HYDROXYAPATITE STRUCTURES INFLUENCE EARLY BONE FORMATION.

Meirelles L, Arvidsson A, Andersson M, Kjellin P, Albrektsson T, Wennerberg A.

Journal of Biomedical Materials Research Part A Volume 87A, Issue 2,2008, pp. 299-307



### THE EFFECT OF CHEMICAL AND NANOTOPOGRAPHICAL MODIFICATIONS ON THE EARLY STAGES OF OSSEOINTEGRATION.

Meirelles L, Currie F, Jacobsson M, Albrektsson T, Wennerberg A.

The International Journal of Oral and Maxillofacial Implants Volume 23, Issue 4, 2008, pp. 641-647



### NANO HYDROXYAPATITE-COATED IMPLANTS IMPROVE BONE NANOMECHANICAL PROPERTIES.

Jimbo R, Coelho PG, Bryington M, Baldassarri M, Tovar N, Currie F, Hayashi M, Janal MN, Andersson

M, Ono D, Vandeweghe S, Wennerberg

A.J Dent Res. 2012;91(12):1172-7



Scanning Electron Microscopy demonstrating osteoblastic cell on HAnano® surface. Courtesy: Cavalcanti JH, Tanaka M, Bezerra FJ, CBPF RJ.

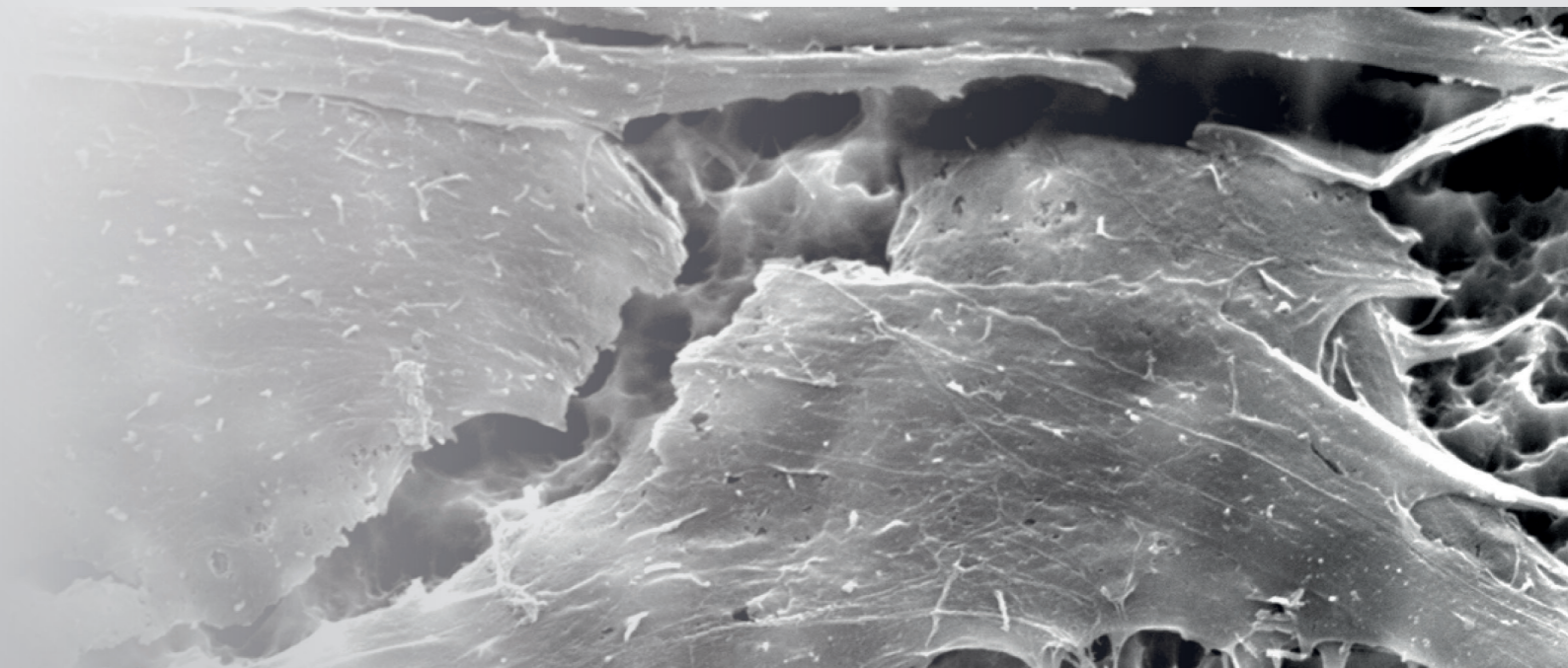

# UNITITE® HIGH LEVEL OF EXCELLENCE



Unitite® was developed based on more than 10 years of studies in important universities of the world. That is how we have been able to verify its efficacy through clinical and scientific results.

In the following chart we observed the results of Unitite® with respect to marginal bone loss performed in an animal study. In this study, Unitite® was compared to implants SLActive (Straumann), TiUnite (Nobel Biocare) and Nanotite (Biomet 3i), with lower bone loss two to four weeks after implant placement.

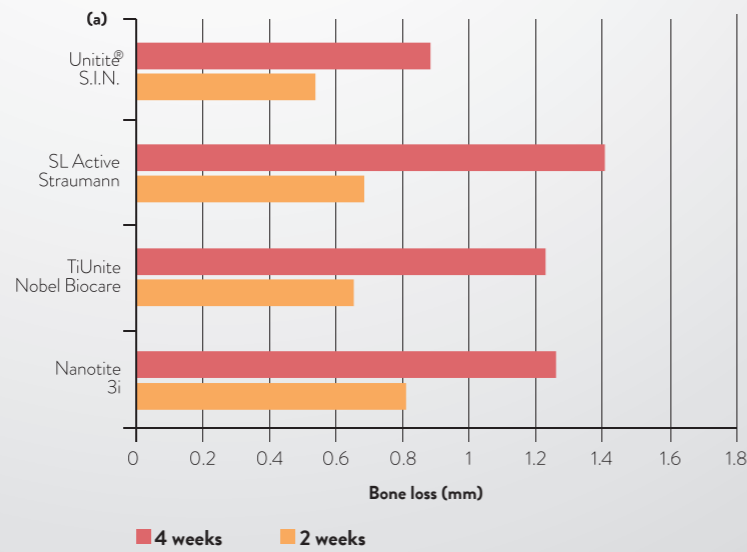

Source: modified from Bonfante et al.

The Unitite® demonstrated excellent results for bone maintenance in finite element analysis.

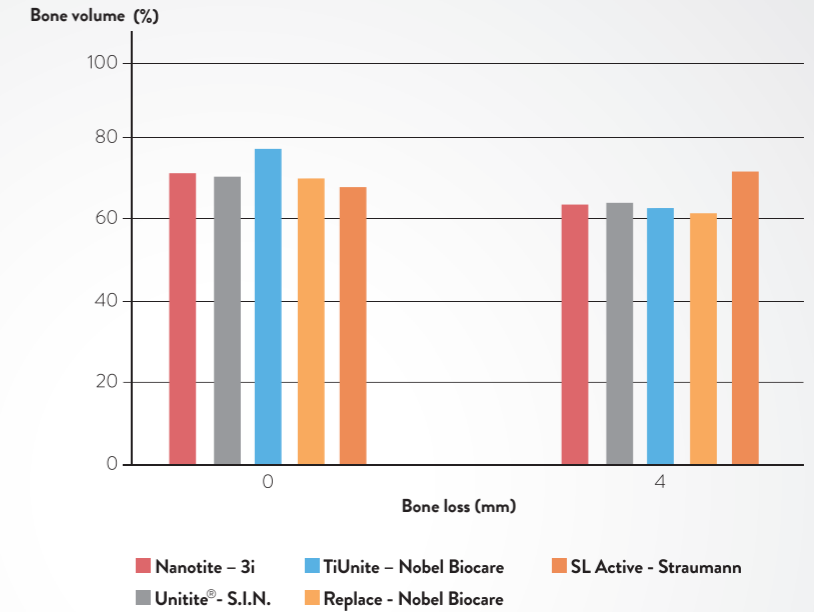

Source: modified from Shunmugasamy et al.

By analyzing the results demonstrated below, it was found that the dissipation of forces in the bone tissue of the Unitite® is comparable to the main brands of dental implants.

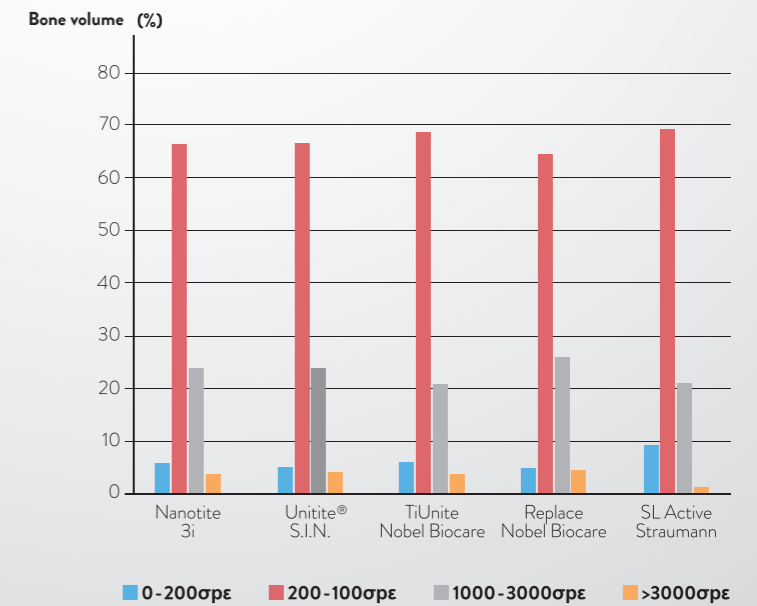

Source: modified from Shunmugasamy et al.

# UNITITE® SLIM

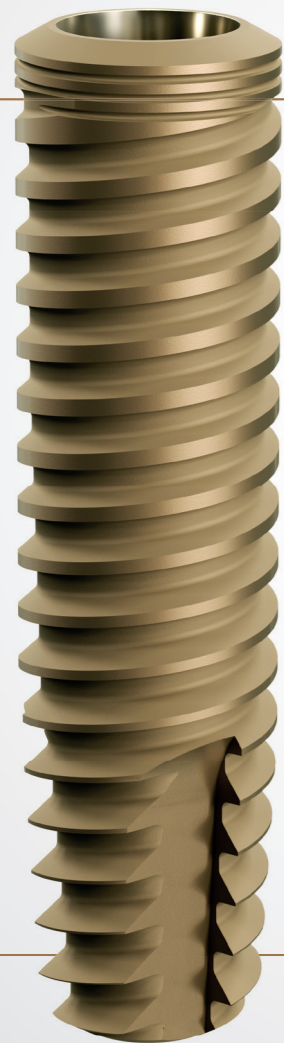

UNITITE® SLIM

### INDICATIONS FOR CLINICAL USE:

- > 2.9 – Central and lateral incisors (mandible)  
lateral incisors (maxilla)

- Offers three different lengths for your surgical planning.
- Only 2.9 mm diameter: Unitite® Slim provides rehabilitation in narrow areas and limited interdental spaces, such as the upper lateral incisors, and lower incisors areas.
- More safety: the reduced dimension protects vital oral structures, and their vascularization.
- Morse Taper: biomechanical superiority of prosthetic connections with internal angle of 3 degrees.
- Produced with Cold-Worked grade 4 Titanium: This production technique offers long-term stability and mechanical strength for thin-walled implants.

- > Indicated for all type of bones
- > **Recommended 1.5 mm infra-bone installation**
- > Speed of the initial drills: 1200 rpm
- > Speed of the drill 2.7mm: 800 rpm
- > Speed of the bone tap 2.9mm: 20 rpm\*
- > Implant Insertion Speed: 20 to 40 rpm
- > **Maximum Torque: 45 N.cm**
- > Includes cover screw of 2.0 mm
- > Suitable for late loading: As from 60 days

\* For bone types I and II, the bone tap is required to ensure the correct healing process.

## DRILLING SEQUENCE GUIDE

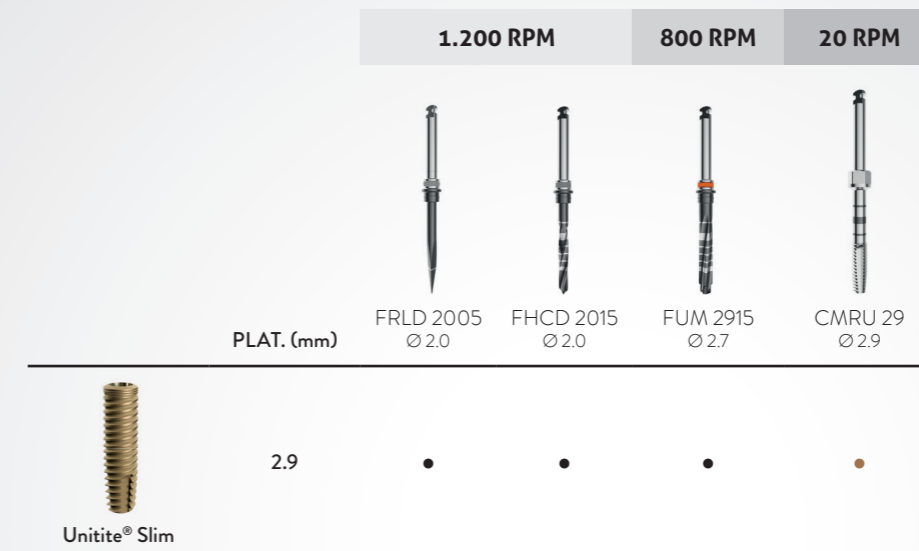

- For bone types I and II, the bone tap is required to ensure the correct healing process.

## TECHNICAL INFORMATION

### UCMS 29xxN

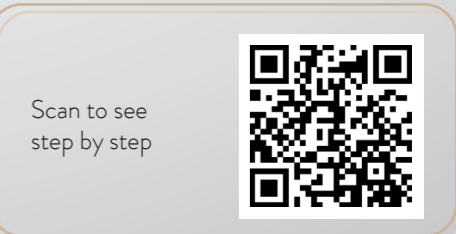
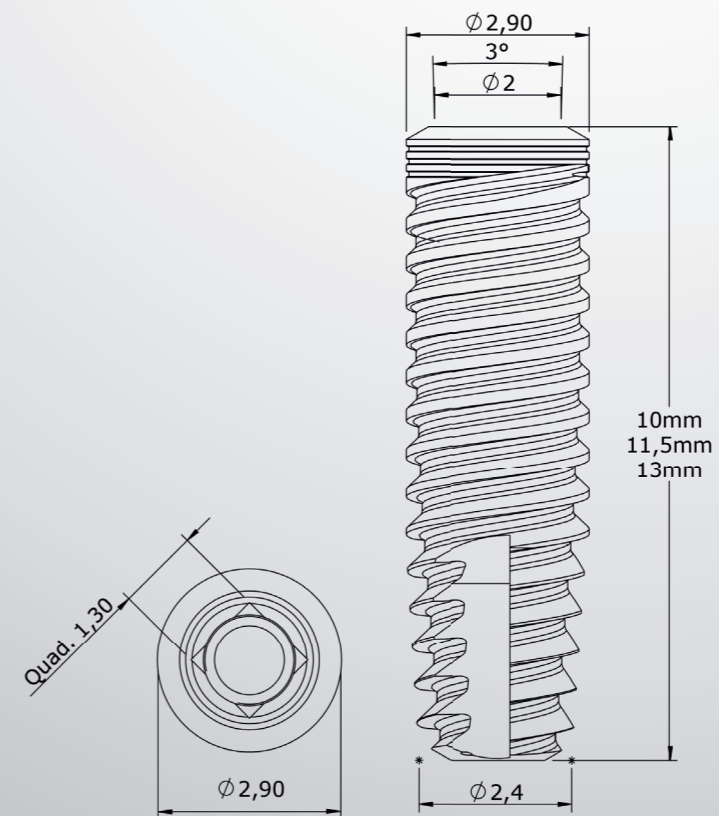

UNITITE SLIM

# UNITITE® SLIM PROSTHETIC SEQUENCE

UNIVERSAL ABUTMENT SEQUENCE (ANALOG AND DIGITAL)

Cemented Single



**IMPLANT**

CODE	DIAM. (mm)	LENGTH (mm)
UCMS 2910N	2.9	10.0
UCMS 2911N	2.9	11.5
UCMS 2913N	2.9	13.0



**TITANIUM HEALING CAP**

CODE	DIAM. (mm)	LENGTH (mm)
CIMUS 3315	3.3	1.5
CIMUS 3325	3.3	2.5
CIMUS 3335	3.3	3.5
CIMUS 3345	3.3	4.5



**PEEK HEALING CAP**

CODE	PROFILE DIAM. (mm)	LENGTH (mm)
CPUS 0404	4.0	4.0
CPUS 0408	4.0	8.0



**UNIVERSAL ABUTMENT**

STRAIGHT CODE	DIAM. (mm)	TRANSMUCOSAL HEIGHT (mm)	CEMENTATION HEIGHT (mm)
AISITS 334008	3.3	0.8	4.0
AISITS 334015	3.3	1.5	4.0
AISITS 334025	3.3	2.5	4.0
AISITS 334035	3.3	3.5	4.0
AISITS 334045	3.3	4.5	4.0
AISITS 334055	3.3	5.5	4.0
AISITS 336008	3.3	0.8	6.0
AISITS 336015	3.3	1.5	6.0
AISITS 336025	3.3	2.5	6.0
AISITS 336035	3.3	3.5	6.0
AISITS 336045	3.3	4.5	6.0
AISITS 336055	3.3	5.5	6.0

15 N.cm



**POLYACETAL IMPRESSION TRANSFER**

CODE	DIAM. (mm)	LENGTH (mm)	COLOR
TSIT 3340	3.3	4.0	Yellow
TSIT 3360	3.3	6.0	Blue



**ANALOG**

CODE	DIAM. (mm)	LENGTH (mm)
ASIT 3340	3.3	4.0
ASIT 3360	3.3	6.0



**POLYACETAL CALCINABLE CYLINDER**

CODE	DIAM. (mm)	LENGTH (mm)
CPSIT 3340	3.3	4.0
CPSIT 3360	3.3	6.0



**ACRYLIC TEMPORARY CYLINDER**

CODE	DIAM. (mm)	LENGTH (mm)
CCSIT 3340	3.3	4.0
CCSIT 3360	3.3	6.0



**UNIVERSAL ABUTMENT SCANNING JIG**





CODE	DIAM. (mm)	HEIGHT (mm)
JBSIT 3340	3.3	4.0
JBSIT 3360	3.3	6.0
JBSIT 4540	4.5	4.0
JBSIT 4560	4.5	6.0



**UNIVERSAL ABUTMENT DIGITAL ANALOG**

CODE	DIAM. (mm)	HEIGHT (mm)
ADUA 3340	3.3	4.0
ADUA 3360	3.3	6.0
ADUA 4540	4.5	4.0
ADUA 4560	4.5	6.0

## DRIVERS

	Driver Handpiece Hex. 1.2mm Short (CTH 1220)		Driver Ratchet Hex. 1.2mm Short (CDHC 20)
	Driver Handpiece Hex. 1.2mm Medium (CTH 1224)		Driver Ratchet Hex. 1.2mm (CDHC 24)
	Driver Handpiece Hex. 1.2mm Long (CTH 1230)		

For installation and removal of PEEK healing caps compatible with Unitite® Slim, it is necessary to purchase the CICS and CRCS keys separately.

Check product availability in your country.

UNITITE SLIM

- \* Analog sequence
- \* Digital sequence
- \* Hex driver
- ⊙ \* Anti-Rotational component
- \* Squared Screw
- ⊕ \* Abutment Screw
- ⊙ \* Rotational component

# UNITITE® SLIM PROSTHETIC SEQUENCE

MICRO MULTI-UNIT ABUTMENT (ANALOG AND DIGITAL)

Single and Multiple screw retained prosthesis



IMPLANT		
CODE	DIAM. (mm)	LENGTH (mm)
UCMS 2910N	2.9	10.0
UCMS 2911N	2.9	11.5
UCMS 2913N	2.9	13.0



MICRO MULTI-UNIT ABUTMENT		
CODE	DIAM. (mm)	TRANSMUCOSAL LENGTH (mm)
MMAMS 3315	3.5	1.5
MMAMS 3325	3.5	2.5
MMAMS 3335	3.5	3.5



ABUTMENT PROTECTOR
CODE
PMM 33

DRIVERS

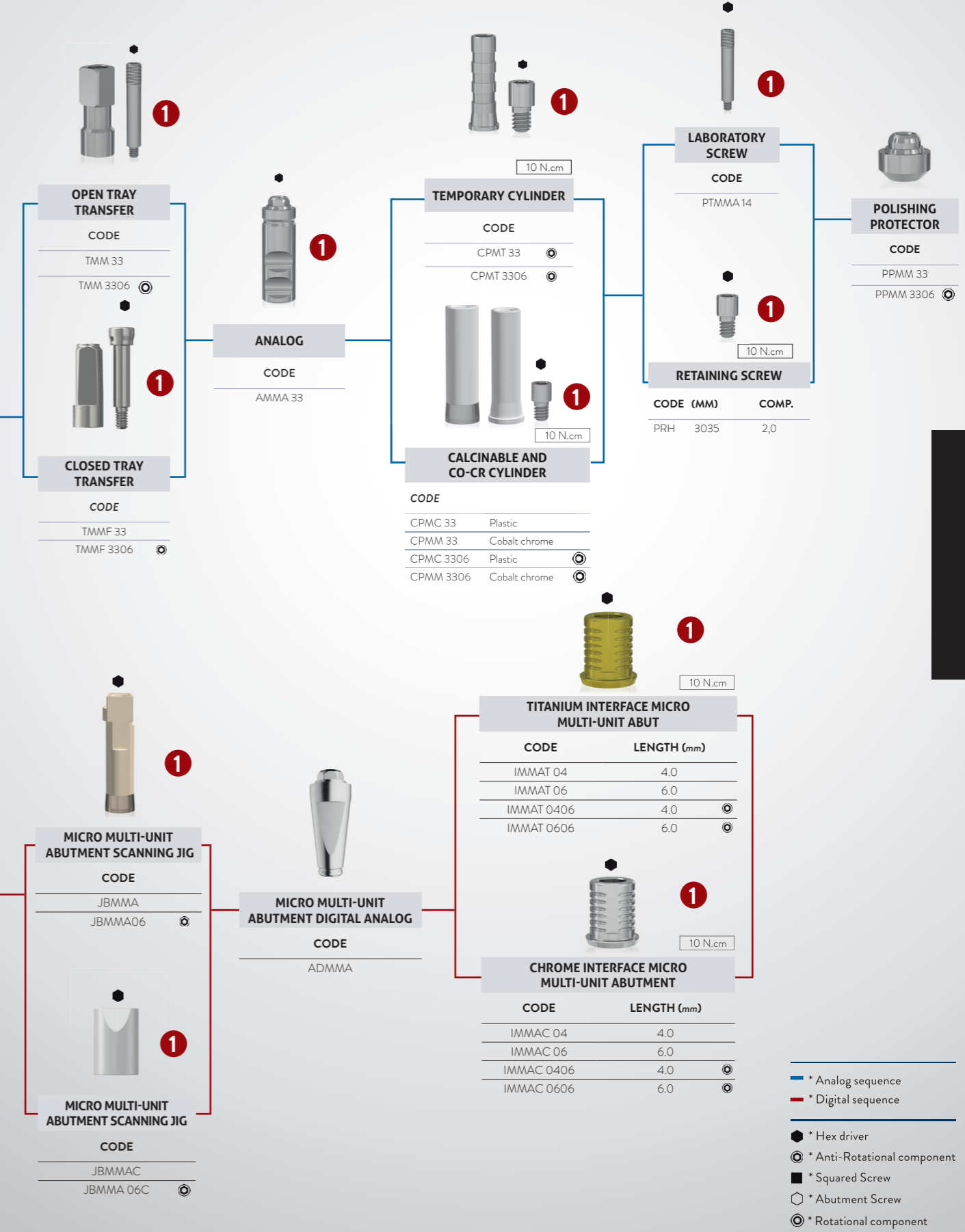
- \* Analog sequence
- \* Digital sequence
- ⬤ \* Hex driver
- ⊙ \* Anti-Rotational component
- \* Squared Screw
- ⬢ \* Abutment Screw
- ⊙ \* Rotational component

Check product availability in your country.

UNITITE SLIM

# UNITITE® SLIM PROSTHETIC SEQUENCE

OVERDENTURE EQUATOR

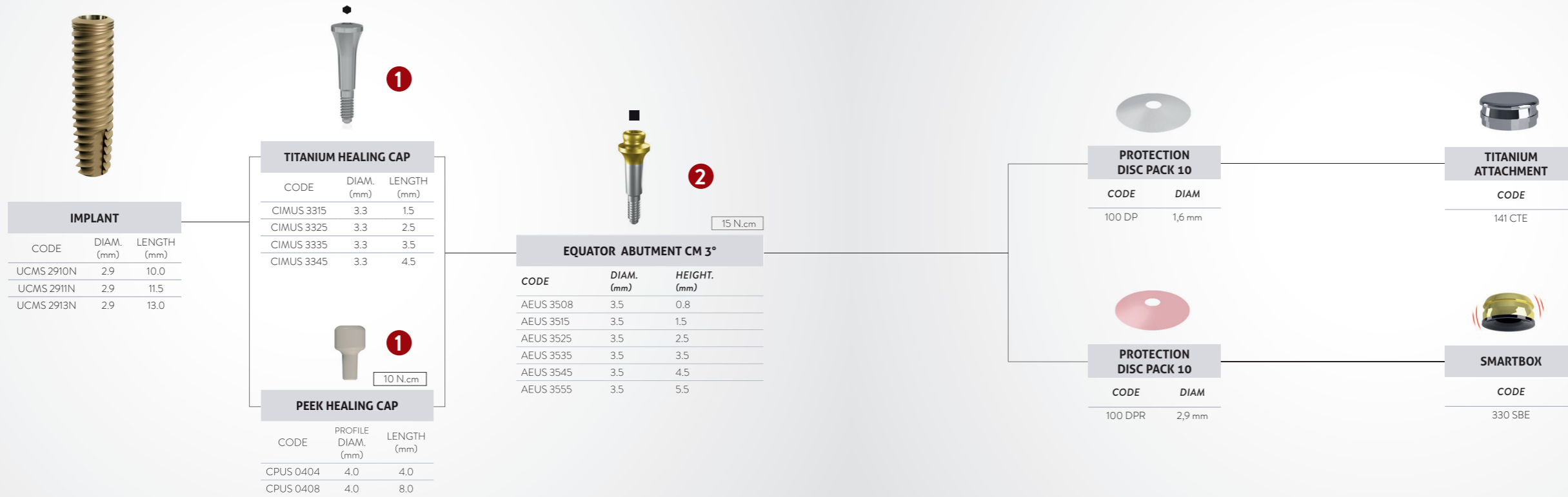

UNITITE SLIM

## DRIVERS

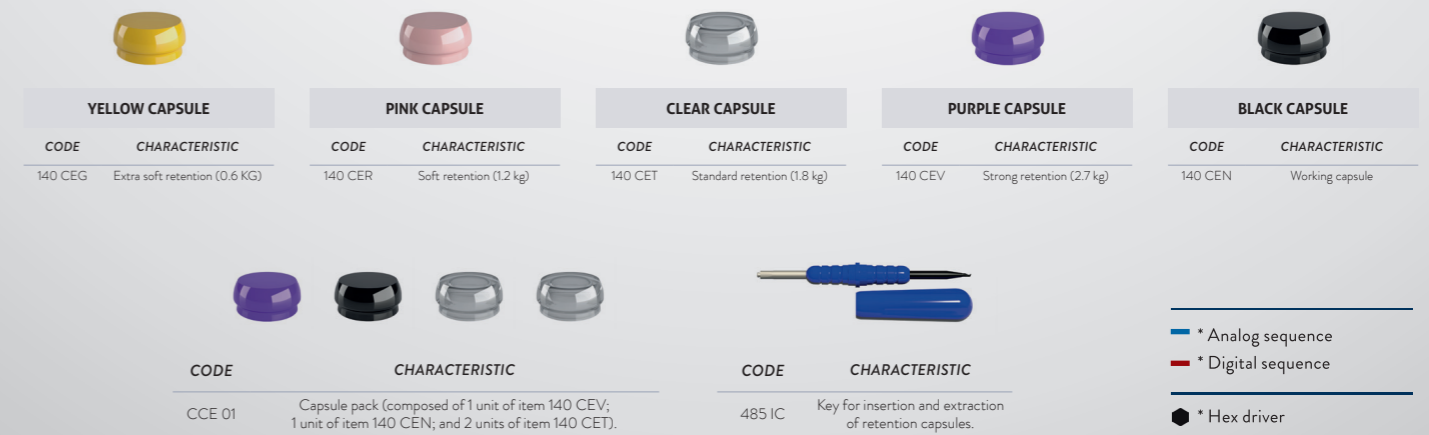

For installation and removal of PEEK healing caps compatible with Unitite® Slim, it is necessary to purchase the CICS and CRCS keys separately.

Check product availability in your country.

- \* Analog sequence
- \* Digital sequence
- Hex driver
- ⊙ \* Anti-Rotational component
- \* Squared Screw
- ⊕ \* Abutment Screw
- ⊙ \* Rotational component

# UNITITE® COMPACT



UNITITE® COMPACT

- Unitite® Compact is indicated for reduced vertical bone availability in the maxilla and mandible.
- Offers diversities of sizes: three lengths in three different diameters.
- Reduces the need of complex surgeries of vertical bone augmentation.
- High performance: adds high stability and predictability to results in cases with reduced bone height.
- Prosthetic Versatility: possibility to perform multiple screwed or single cemented prosthesis.
- Morse Taper Platform: 4° internal angle allows excellent prosthetic stability and longevity of the implant.

### INDICATIONS FOR CLINICAL USE:

- 4.0 - Canines, premolars, and molars
- 5.0 - Molars
- 6.0 - Molars

- > Indicated for all type of bones.
- > **Recommended bone level installation.**
- > Speed of the initial drills: 1200 rpm.
- > Speed of the drills 2.7 to 5.8mm: 800 rpm.
- > Speed of the bone tap from 4.0 to 6.0mm: 20 rpm\*.
- > Implant Insertion Speed 20 to 40 rpm.
- > **Maximum Torque: 60 N.cm.**
- > Includes cover screw of 0 mm.
- > Suitable for late loading: As from 60 days.

\* For bone types I and II, the bone tap is required to ensure the correct healing process.

## DRILLING SEQUENCE GUIDE

Scan to see step by step



	1.200 RPM				800 RPM						20 RPM		
	FRLD 2005 Ø 2.0	FHCD 2015 Ø 2.0	FUM 2915 Ø 2.7	FUM 3515 Ø 3.3	FPUC 3338 Ø 3,3/Ø3,8	FHCD 3215 Ø 3.8	FPUC 3848 Ø3,8/Ø4,8	FHCD 4215 Ø 4.8	FPUC 4858 Ø4,8/Ø5,0	FHCD 5215 Ø 5.8	CMRUC 40 Ø 4.0	CMRUC 50 Ø 5.0	CMRUC 60 Ø 6.0
	4,0	•	•	•	•	•					•		
	5,0	•	•	•	•	•	•	•				•	
Unitite® Compact	6,0	•	•	•	•	•	•	•	•	•			•

• For bone types I and II, the bone tap is required to ensure the correct healing process.

## TECHNICAL INFORMATION

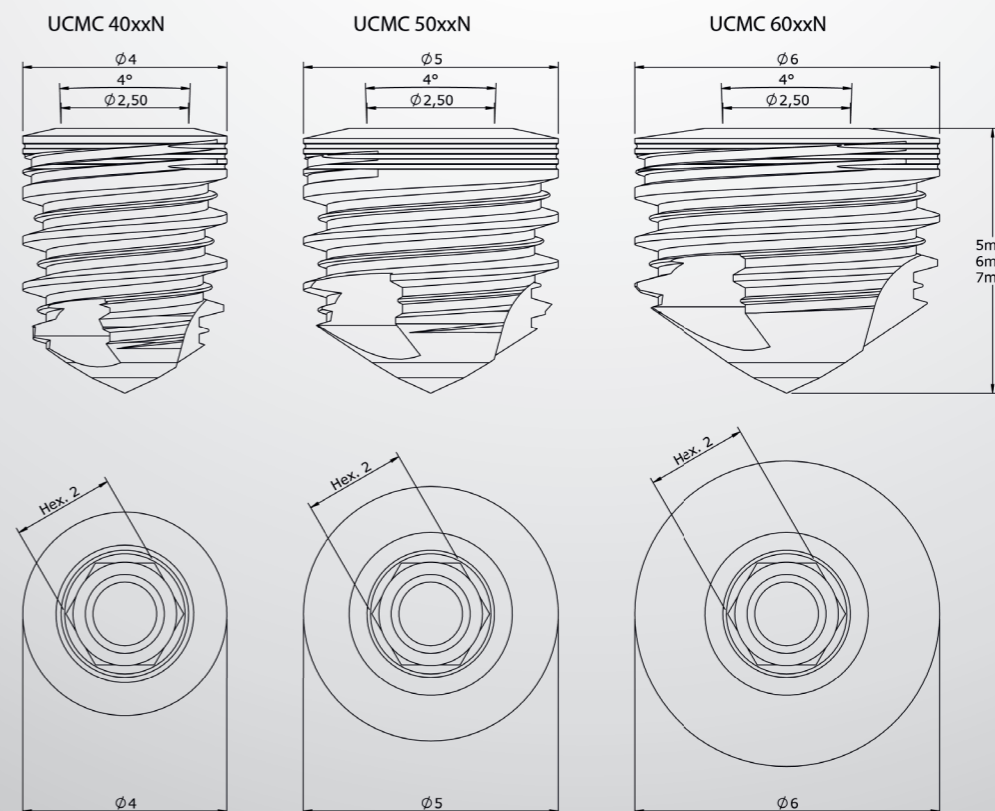

UNITITE COMPACT

# UNITITE® COMPACT PROSTHETIC SEQUENCE

UNIVERSAL ABUTMENT - SEQUENCE WITH PROSTHETIC INTERMEDIATE  
(ANALOG AND DIGITAL)

Cemented Single

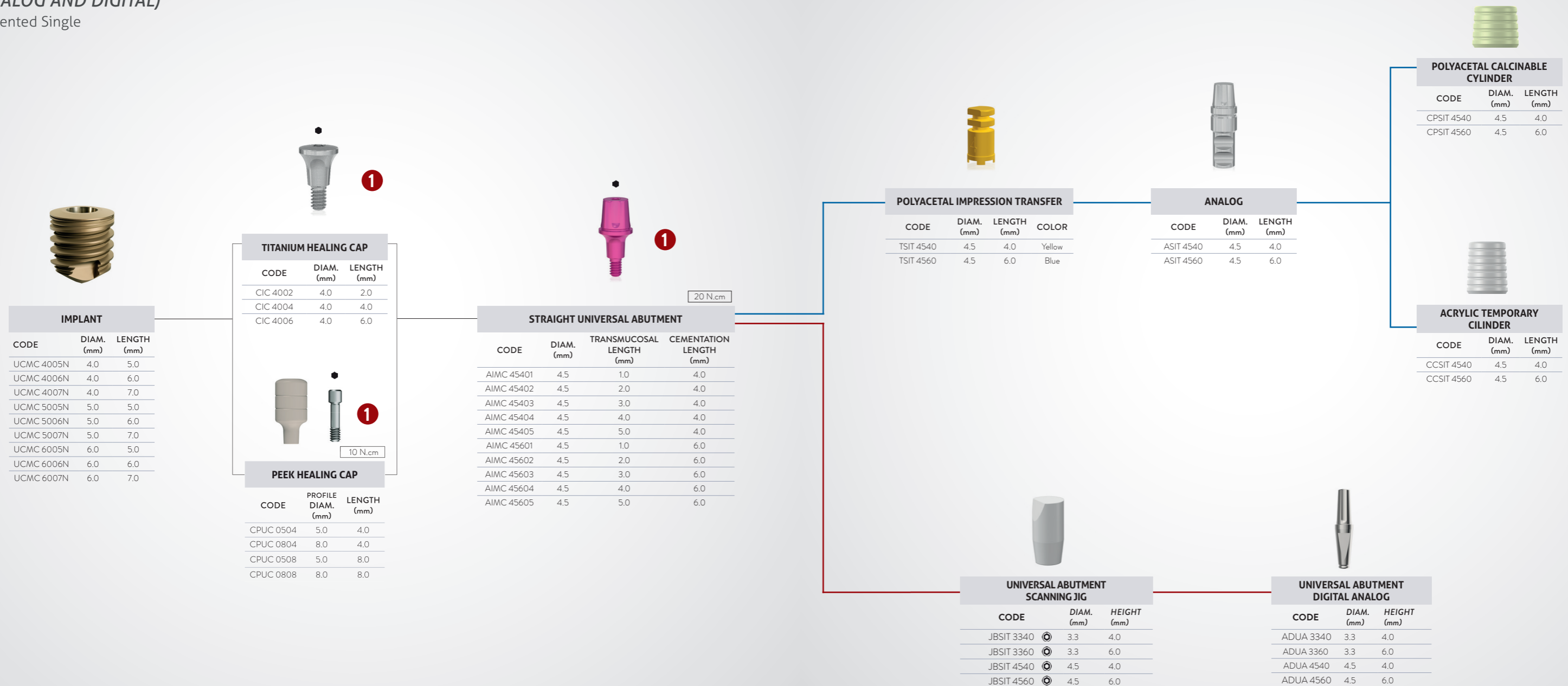

**IMPLANT**

CODE	DIAM. (mm)	LENGTH (mm)
UCMC 4005N	4.0	5.0
UCMC 4006N	4.0	6.0
UCMC 4007N	4.0	7.0
UCMC 5005N	5.0	5.0
UCMC 5006N	5.0	6.0
UCMC 5007N	5.0	7.0
UCMC 6005N	6.0	5.0
UCMC 6006N	6.0	6.0
UCMC 6007N	6.0	7.0

**TITANIUM HEALING CAP**

CODE	DIAM. (mm)	LENGTH (mm)
CIC 4002	4.0	2.0
CIC 4004	4.0	4.0
CIC 4006	4.0	6.0

**PEEK HEALING CAP**

CODE	PROFILE DIAM. (mm)	LENGTH (mm)
CPUC 0504	5.0	4.0
CPUC 0804	8.0	4.0
CPUC 0508	5.0	8.0
CPUC 0808	8.0	8.0

**STRAIGHT UNIVERSAL ABUTMENT**

CODE	DIAM. (mm)	TRANSMUCOSAL LENGTH (mm)	CEMENTATION LENGTH (mm)
AIMC 45401	4.5	1.0	4.0
AIMC 45402	4.5	2.0	4.0
AIMC 45403	4.5	3.0	4.0
AIMC 45404	4.5	4.0	4.0
AIMC 45405	4.5	5.0	4.0
AIMC 45601	4.5	1.0	6.0
AIMC 45602	4.5	2.0	6.0
AIMC 45603	4.5	3.0	6.0
AIMC 45604	4.5	4.0	6.0
AIMC 45605	4.5	5.0	6.0

**POLYACETAL IMPRESSION TRANSFER**

CODE	DIAM. (mm)	LENGTH (mm)	COLOR
TSIT 4540	4.5	4.0	Yellow
TSIT 4560	4.5	6.0	Blue

**ANALOG**

CODE	DIAM. (mm)	LENGTH (mm)
ASIT 4540	4.5	4.0
ASIT 4560	4.5	6.0

**POLYACETAL CALCINABLE CYLINDER**

CODE	DIAM. (mm)	LENGTH (mm)
CPSIT 4540	4.5	4.0
CPSIT 4560	4.5	6.0

**ACRYLIC TEMPORARY CILINDER**

CODE	DIAM. (mm)	LENGTH (mm)
CCSIT 4540	4.5	4.0
CCSIT 4560	4.5	6.0

**UNIVERSAL ABUTMENT SCANNING JIG**

CODE	DIAM. (mm)	HEIGHT (mm)
JBSIT 3340	3.3	4.0
JBSIT 3360	3.3	6.0
JBSIT 4540	4.5	4.0
JBSIT 4560	4.5	6.0

**UNIVERSAL ABUTMENT DIGITAL ANALOG**

CODE	DIAM. (mm)	HEIGHT (mm)
ADUA 3340	3.3	4.0
ADUA 3360	3.3	6.0
ADUA 4540	4.5	4.0
ADUA 4560	4.5	6.0

DRIVERS

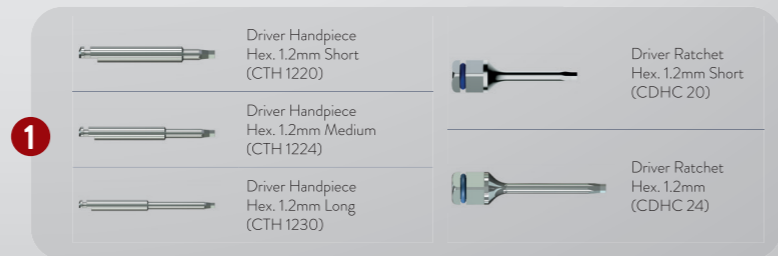

Check product availability in your country.

- \* Analog sequence
- \* Digital sequence
- \* Hex driver
- ⊙ \* Anti-Rotational component
- \* Squared Screw
- ⊕ \* Abutment Screw
- ⊗ \* Rotational component

UNITITE COMPACT

# UNITITE® COMPACT PROSTHETIC SEQUENCE

MULTI-UNIT ABUTMENT - SEQUENCE WITH PROSTHETIC INTERMEDIATE  
(ANALOG AND DIGITAL)

Screw-retained multiple partial or full prosthesis

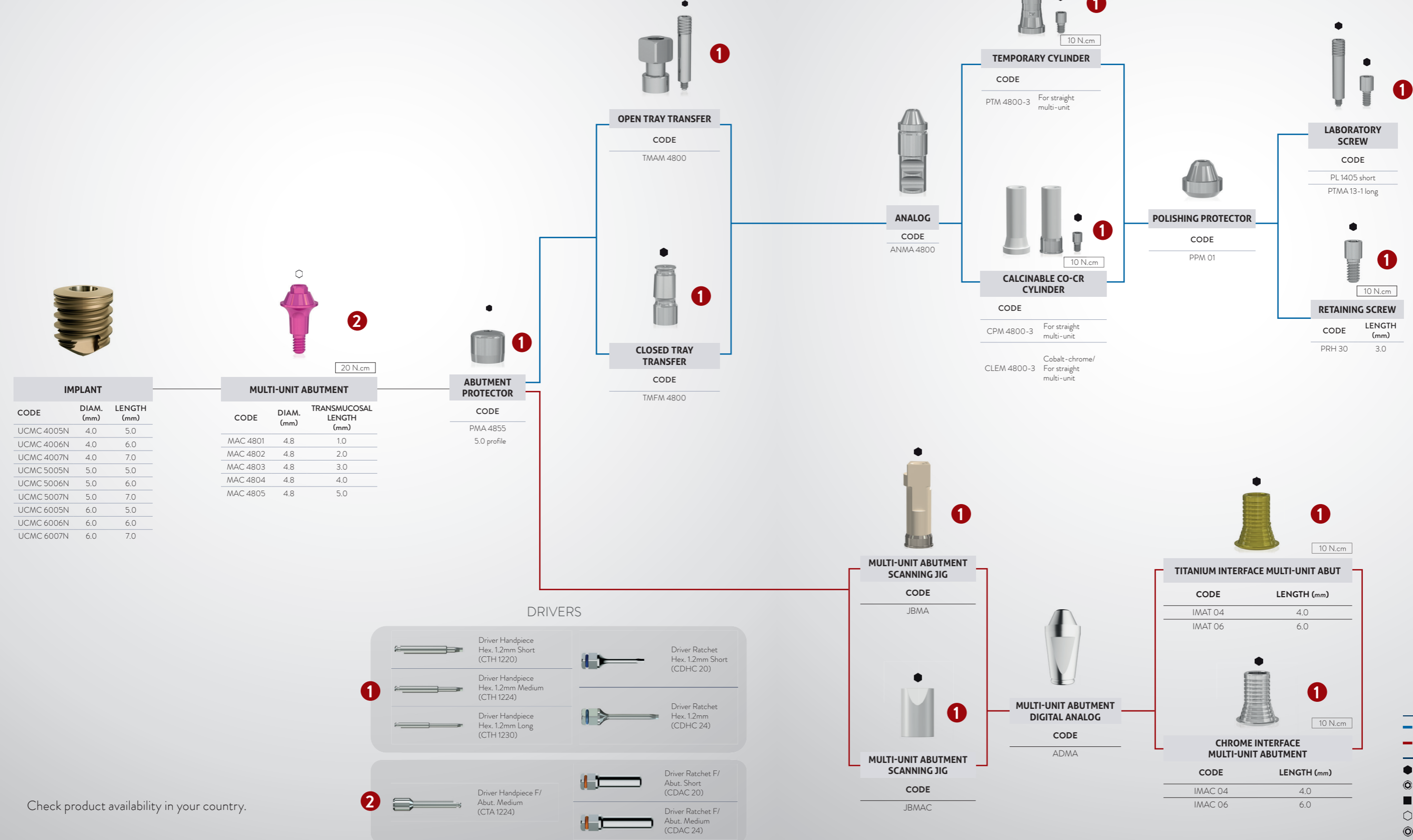

Check product availability in your country.

# UNITITE® COMPACT PROSTHETIC SEQUENCE

MULTIFUNCTIONAL ABUTMENT - SEQUENCE WITH PROSTHETIC INTERMEDIATE  
(ANALOG AND DIGITAL)

Screw-retained single, multiple partial or full prosthesis



IMPLANT		
CODE	DIAM. (mm)	COMP. (mm)
UCMC 4005N	4.0	5.0
UCMC 4006N	4.0	6.0
UCMC 4007N	4.0	7.0
UCMC 5005N	5.0	5.0
UCMC 5006N	5.0	6.0
UCMC 5007N	5.0	7.0
UCMC 6005N	6.0	5.0
UCMC 6006N	6.0	6.0
UCMC 6007N	6.0	7.0



MULTIFUNCTIONAL ABUTMENT		
CODE	DAM. (mm)	TRANSMUCOSAL LENGTH (mm)
AMCMC 4801	4.8	1.0
AMCMC 4802	4.8	2.0
AMCMC 4803	4.8	3.0
AMCMC 4804	4.8	4.0
AMCMC 4805	4.8	5.0

Use hexagonal driver 1.6 mm



ABUTMENT PROTECTOR	
CODE	
PAM 48	

DRIVERS

	Driver Handpiece Hex. 1.2mm Short (CTH 1220)		Driver Ratchet Hex. 1.2mm Short (CDHC 20)
	Driver Handpiece Hex. 1.2mm Medium (CTH 1224)		Driver Ratchet Hex. 1.2mm (CDHC 24)
	Driver Handpiece Hex. 1.2mm Long (CTH 1230)		
	Driver Handpiece Hex. 1.6mm Short (CTH 1620)		Driver Ratchet Hex. 1.6mm Short (CCH 1620)
	Driver Handpiece Hex. 1.6mm Medium (CTH 1624)		Driver Ratchet Hex. 1.6mm Medium (CCH 1624)

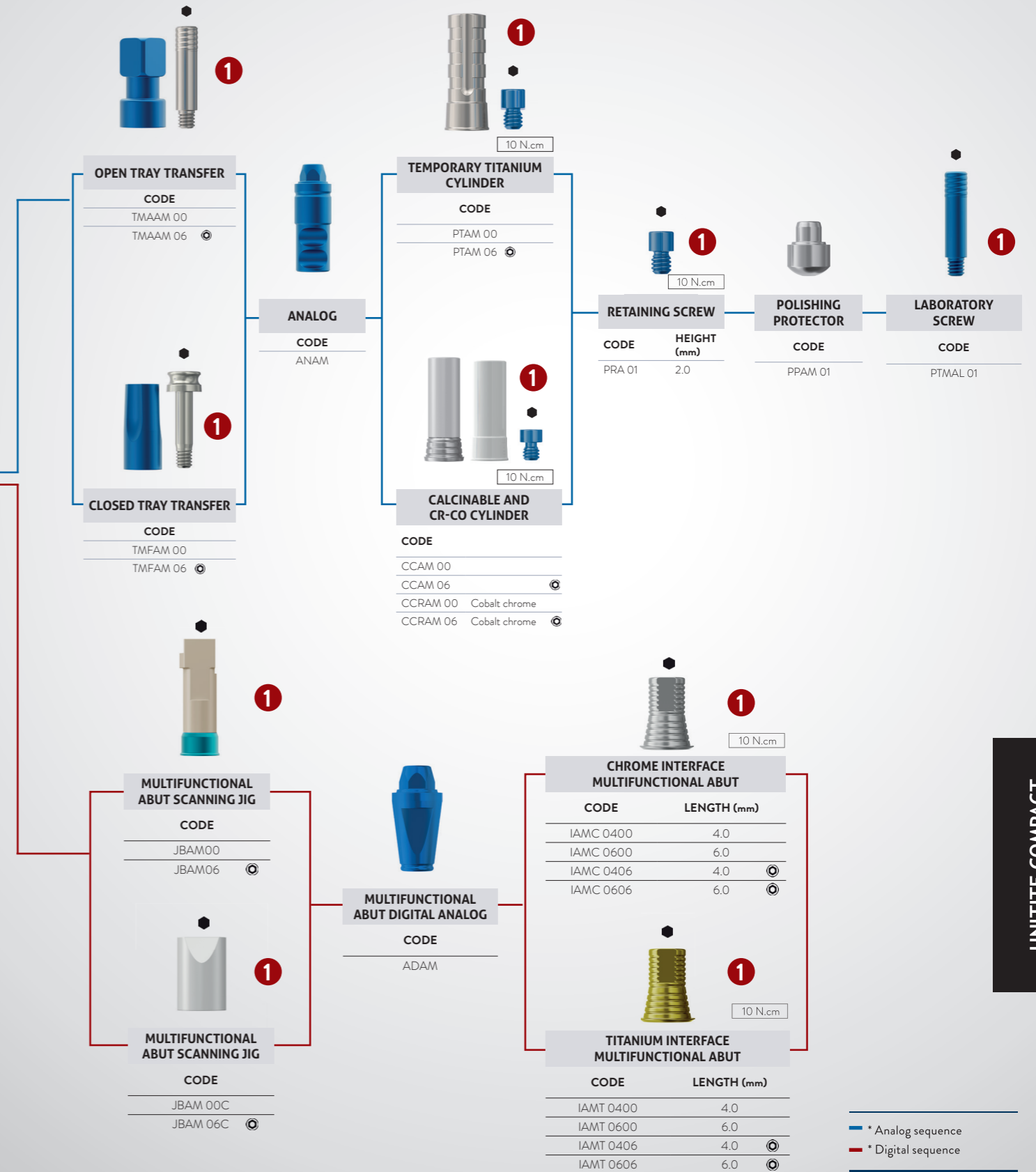

- \* Analog sequence
- \* Digital sequence
- Hex driver
- ⊙ \* Anti-Rotational component
- \* Squared Screw
- ⊕ Abutment Screw
- ⊙ \* Rotational component

Check product availability in your country.

# UNITITE® COMPACT PROSTHETIC SEQUENCE

OVERDENTURE EQUATOR

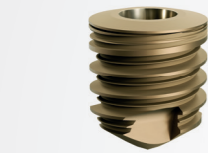

IMPLANT		
CODE	DIAM. (mm)	LENGTH (mm)
UCMC 4005N	4.0	5.0
UCMC 4006N	4.0	6.0
UCMC 4007N	4.0	7.0
UCMC 5005N	5.0	5.0
UCMC 5006N	5.0	6.0
UCMC 5007N	5.0	7.0
UCMC 6005N	6.0	5.0
UCMC 6006N	6.0	6.0
UCMC 6007N	6.0	7.0

**TITANIUM HEALING CAP**

CODE	DIAM. (mm)	LENGTH (mm)
CIC 4002	4.0	2.0
CIC 4004	4.0	4.0
CIC 4006	4.0	6.0

**PEEK HEALING CAP**

CODE	PROFILE DIAM. (mm)	LENGTH (mm)
CPUC 0504	5.0	4.0
CPUC 0804	8.0	4.0
CPUC 0508	5.0	8.0
CPUC 0808	8.0	8.0

1

1

1

2



EQUATOR ABUTMENT CM 4°		
CODE	DIAM. (mm)	HEIGHT (mm)
AEUC 4001	4.0	1.0
AEUC 4002	4.0	2.0
AEUC 4003	4.0	3.0
AEUC 4004	4.0	4.0
AEUC 4005	4.0	5.0
AEUC 4006	4.0	6.0

2

20 N.cm

## DRIVERS

**1**

	Driver Handpiece Hex. 1.2mm Short (CTH 1220)		Driver Ratchet Hex. 1.2mm Short (CDHC 20)
	Driver Handpiece Hex. 1.2mm Medium (CTH 1224)		Driver Ratchet Hex. 1.2mm (CDHC 24)
	Driver Handpiece Hex. 1.2mm Long (CTH 1230)		

**2**

	Driver Handpiece Squa. 1.3mm Short (CTQ 20)		Driver Ratchet Squa. 1.3mm Short (CQTM 20)
	Driver Handpiece Squa. 1.3mm Medium (CTQ 24)		Driver Ratchet Squa. 1.3mm Medium (CQTM 24)
	Driver Handpiece Squa. 1.3mm Long (CTQ 30)		

**PROTECTION DISC PACK 10**

CODE	DIAM
100 DP	1,6 mm

**TITANIUM ATTACHMENT**

CODE
141 CTE

**PROTECTION DISC PACK 10**

CODE	DIAM
100 DPR	2,9 mm

**SMARTBOX**

CODE
330 SBE

**YELLOW CAPSULE**

CODE	CHARACTERISTIC
140 CEG	Extra soft retention (0.6 KG)

**PINK CAPSULE**

CODE	CHARACTERISTIC
140 CER	Soft retention (1.2 kg)

**CLEAR CAPSULE**

CODE	CHARACTERISTIC
140 CET	Standard retention (1.8 kg)

**PURPLE CAPSULE**

CODE	CHARACTERISTIC
140 CEV	Strong retention (2.7 kg)

**BLACK CAPSULE**

CODE	CHARACTERISTIC
140 CEN	Working capsule

**CODE** CCE 01 **CHARACTERISTIC** Capsule pack (composed of 1 unit of item 140 CEV; 1 unit of item 140 CEN; and 2 units of item 140 CET).

**CODE** 485 IC **CHARACTERISTIC** Key for insertion and extraction of retention capsules.

UNITITE SLIM

- \* Analog sequence
- \* Digital sequence
- \* Hex driver
- \* Anti-Rotational component
- \* Squared Screw
- \* Abutment Screw
- \* Rotational component

# UNITITE® SURGICAL KIT

A SINGLE KIT FOR THE ENTIRE UNITITE® LINE.

To make your daily routine even more convenient and efficient, we have developed the Unitite® single surgical kit for installing the full line: Unitite® Prime, Unitite® Slim, and Unitite® Compact.

Unique drills with DLC (Diamond like carbon):

- Less bone heating.
- Increased durability.
- High cutting power.
- Sharper angle.

Mucosa meters: Available for the complete line, helps in the measurement and choice of prosthetic components.



Reduced number of drills required for osteotomy.

Accurate fits of all parts regardless of the position or movement.

Torque wrench. Bidigital adapter included.

Inclined tray for easy viewing during the surgical procedure.

Ease of clinical use through color-coding.

Compact format facilitates sterilization even in smaller autoclaves.

**INSTALLATION OF THE UNITITE IMPLANTS SHOULD ONLY BE DONE WITH THE UNITITE® SURGICAL KIT. AVOID UNDER-DRILLING.**

# ORGANIZING BOX

UNITITE® SURGICAL KIT



- |  |   |  |
|--|---|--|
| <b>01</b> TWIST DRILL Ø2,0X15MM (FHCD 2015)        | <b>17</b> TWIST DRILL Ø4,25X15MM (FHCD 4215)            | <b>33</b> LONG SLIM WRENCH DRIVER (CCUS 24)        |
| <b>02</b> DRILL UNITITE Ø2,6X15MM (FUM 2915)       | <b>18</b> TWIST DRILL Ø5,25X15MM (FHCD 5215)            | <b>34</b> LONG MORSE HANDPIECE DRIVER (CTUM 24)    |
| <b>03</b> DRILL UNITITE Ø3,0X15MM (FUM 3015)       | <b>19</b> SHORT DIRECTION INDICATOR (DU 100)            | <b>35</b> LONG MORSE TAPER WRENCH DRIVER (CCUM 24) |
| <b>04</b> DRILL MORSE UNITITE Ø3,8X15MM (FUM 3815) | <b>20</b> SHORT DIRECTION INDICATOR (DU 100)            | <b>36</b> SHORT SLIM HANDPIECE DRIVER (CTUS 20)    |
| <b>05</b> DRILL MORSE UNITITE Ø3,8X15MM (FUM 4315) | <b>21</b> LONG DIRECTION INDICATOR (DU 200)             | <b>37</b> SHORT SLIM WRENCH DRIVER (CCUS 20)       |
| <b>06</b> DRILL UNITITE Ø4,5X15MM (FUM 5015)       | <b>22</b> LONG DIRECTION INDICATOR (DU 200)             | <b>38</b> SHORT MORSE HANDPIECE DRIVER (CTUM 20)   |
| <b>07</b> PILOT DRILL Ø3,3/Ø3,8MM (FPLC 3338)      | <b>23</b> 1.2 HEX DRIVER (CDH 1234)                     | <b>39</b> SHORT MORSE WRENCH DRIVER (CCUM 20)      |
| <b>08</b> PILOT DRILL Ø3,8/Ø4,8MM (FPLC 3848)      | <b>24</b> SCREW TAP - COMPACT Ø4,0MM (CMRUC 40)         | <b>40</b> LONG COMPACT HANDPIECE DRIVER (CTUC 24)  |
| <b>09</b> PILOT DRILL Ø4,8/Ø5,8MM (FPLC 4858)      | <b>25</b> SCREW TAP - COMPACT Ø5,0MM (CMRUC 50)         | <b>41</b> LONG COMPACT WRENCH DRIVER (CCUC 24)     |
| <b>10</b> DRILL SPADE Ø2,0MM (FPLD 2005)           | <b>26</b> SCREW TAP - COMPACT Ø6,0MM (CMRUC 60)         | <b>42</b> SHORT COMPACT HANDPIECE DRIVER (CTUC 20) |
| <b>11</b> SCREW TAP Ø2,9MM (CMRU 29)               | <b>27</b> DRIVER EXTENSOR OF DRILL (EXFN 03)            | <b>43</b> SHORT COMPACT WRENCH DRIVER (CCUC 20)    |
| <b>12</b> SCREW TAP Ø3,5MM (CMRU 35)               | <b>28</b> ADAPTER DRIVER (CSD 01)                       | <b>44</b> DEPTH PROBE (ESPL 25)                    |
| <b>13</b> SCREW TAP Ø5,0MM (CMRU 50)               | <b>29</b> MORSE TAPER PRIME TRANSMUCOSAL METER (MTM 02) | <b>45</b> SURGICAL TORQUE WRENCH (MECC 03)         |
| <b>14</b> SCREW TAP Ø4,3MM (CMRU 43)               | <b>30</b> COMPACT TRANSMUCOSAL METER (MTMC 02)          |  |
| <b>15</b> SCREW TAP Ø5,0MM (CMRU 50)               | <b>31</b> SLIM TRANSMUCOSAL METER (MTMS 02)             |  |
| <b>16</b> TWIST DRILL Ø3,2X15MM (FHCD 3215)        | <b>32</b> LONG SLIM HANDPIECE DRIVER (CTUS 24)          |  |

PRODUCT CODE: KCSU 05  
ORGANIZING BOX: COSU 05

# UNITITE® SAFE DRILL KIT

MAKING YOUR SURGERIES SIMPLER AND MORE PRACTICAL

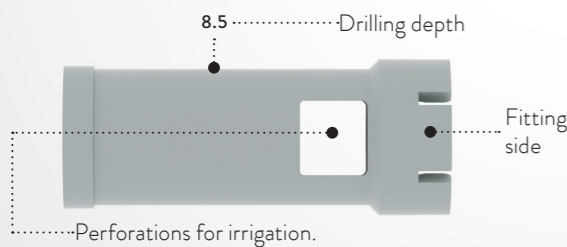

The Unitite® Safe Drill Kit is only compatible with the Unitite® Surgical Kit. For the Morse taper infrabone installation, it is required to use the 1.5mm ring higher than the desired implant height (except for Unitite® Compact).

## UNITITE® SAFE DRILL KIT: KUSD 02      SAFE DRILL ORGANIZING BOX: COUSD 02

CODE	DESCRIPTION
COUSD 02	SAFE DRILL ORGANIZING BOX
LSDD 2005	SAFE DRILL STOPPER ø 2.00/ø 2.70 x 5.0 mm
LSDD 2006	SAFE DRILL STOPPER ø 2.00/ø 2.70 x 6.0 mm
LSDD 2007	SAFE DRILL STOPPER ø 2.00/ø 2.70 x 7.0 mm
LSDD 2085	SAFE DRILL STOPPER ø 2.00/ø 2.70 x 8.5 mm
LSDD 2010	SAFE DRILL STOPPER ø 2.00/ø 2.70 x 10.0 mm
LSDD 2011	SAFE DRILL STOPPER ø 2.00/ø 2.70 x 11.5 mm
LSDD 2013	SAFE DRILL STOPPER ø 2.00/ø 2.70 x 13.0 mm
LSDD 2015	SAFE DRILL STOPPER ø 2.00/ø 2.70 x 15.0 mm
LSDD 3005	SAFE DRILL STOPPER ø 3.00/ø 3.30 x 5.0 mm
LSDD 3006	SAFE DRILL STOPPER ø 3.00/ø 3.30 x 6.0 mm

CODE	DESCRIPTION
LSDD 3085	SAFE DRILL STOPPER ø 3.00/ø 3.30 x 8.5 mm
LSDD 3007	SAFE DRILL STOPPER ø 3.00/ø 3.30 x 7.0 mm
LSDD 3010	SAFE DRILL STOPPER ø 3.00/ø 3.30 x 10.0 mm
LSDD 3011	SAFE DRILL STOPPER ø 3.00/ø 3.30 x 11.5 mm
LSDD 3013	SAFE DRILL STOPPER ø 3.00/ø 3.30 x 13.0 mm
LSDD 3015	SAFE DRILL STOPPER ø 3.00/ø 3.30 x 15.0 mm
LSDD 3805C	SAFE DRILL STOPPER ø 3.80/ø 4.25 x 5.0 mm
LSDD 3806C	SAFE DRILL STOPPER ø 3.80/ø 4.25 x 6.0 mm
LSDD 3807C	SAFE DRILL STOPPER ø 3.80/ø 4.25 x 7.0 mm
LSDD 3885	SAFE DRILL STOPPER ø 3.80/ø 4.25 x 8.5 mm
LSDD 3810	SAFE DRILL STOPPER ø 3.80/ø 4.25 x 10.0 mm

CODE	DESCRIPTION
LSDD 3811	SAFE DRILL STOPPER ø 3.80/ø 4.25 x 11.5 mm
LSDD 3813	SAFE DRILL STOPPER ø 3.80/ø 4.25 x 13.0 mm
LSDD 3815	SAFE DRILL STOPPER ø 3.80/ø 4.25 x 15.0 mm
LSDD 4505C	SAFE DRILL STOPPER ø 4.50/ø 5.80 x 5.0 mm
LSDD 4506C	SAFE DRILL STOPPER ø 4.50/ø 5.80 x 6.0 mm
LSDD 4507C	SAFE DRILL STOPPER ø 4.50/ø 5.80 x 7.0 mm
LSDD 4585	SAFE DRILL STOPPER ø 4.50/ø 5.80 x 8.5 mm
LSDD 4510	SAFE DRILL STOPPER ø 4.50/ø 5.80 x 10.0 mm
LSDD 4511	SAFE DRILL STOPPER ø 4.50/ø 5.80 x 11.5 mm
LSDD 4513	SAFE DRILL STOPPER ø 4.50/ø 5.80 x 13.0 mm
LSDD 4515	SAFE DRILL STOPPER ø 4.50/ø 5.80 x 15.0 mm

# SHORT DRILL KIT

UNITITE® MILLING SYSTEM IS COMPLETE.

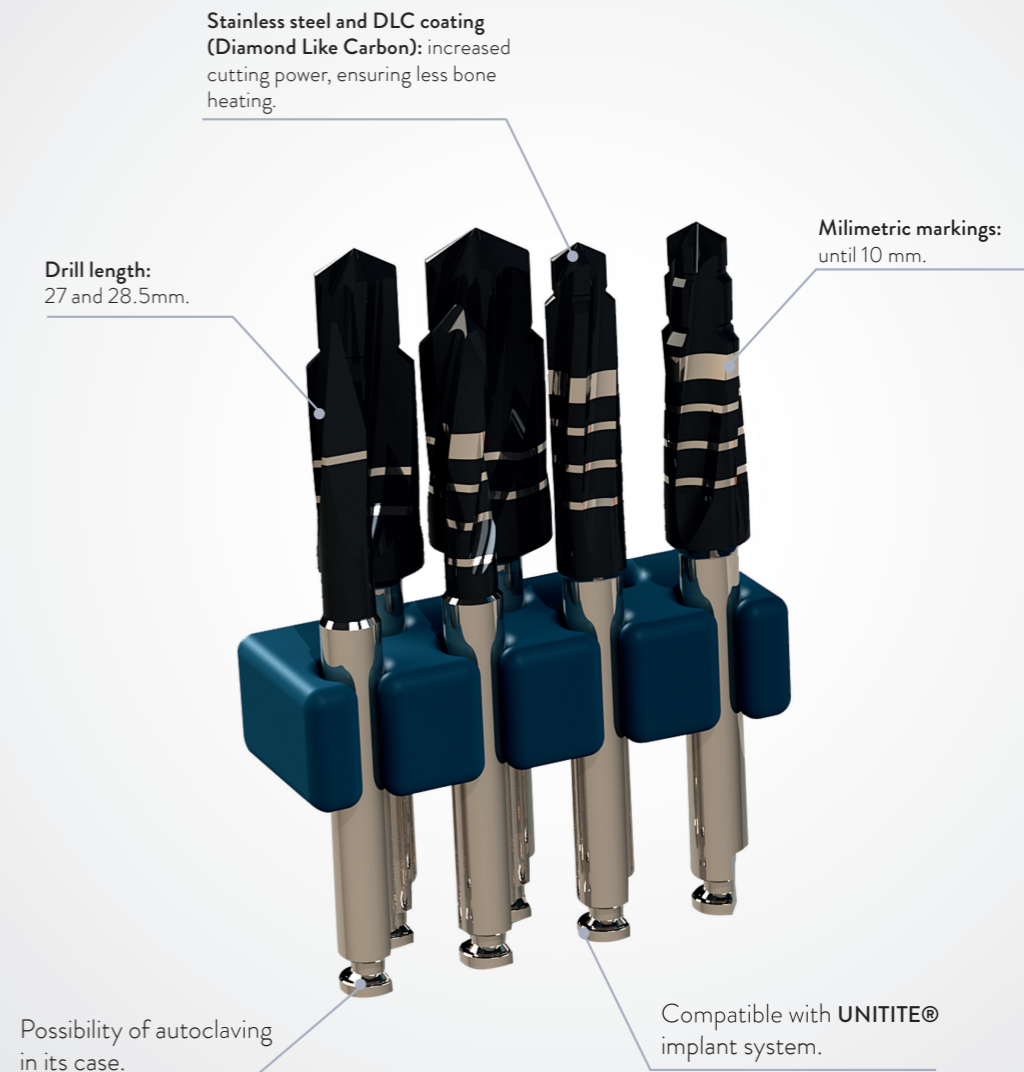

**INDICATION**  
In cases requiring drills with shorter length for patients with limited mouth opening.

## SHORT DRILL KIT: KSDU

CODE	DESCRIPTION	LENGTH	DIAM.	CODE	DESCRIPTION	LENGTH	DIAM.
FRLD 2005C	LANCE DRILL Ø2.0MM SHORT	27	Ø2.00	FUM 3510C	CONICAL DRILL Ø3.3X10MM SHORT	28.5	Ø3.30
FHCD 2010C	HELICAL DRILL Ø2.0 X10MM SHORT	27	Ø2.00	FUM 4310C	CONICAL DRILL Ø4.1X10MM SHORT	28.5	Ø4.10
FUM 2910C	CONICAL DRILL Ø2.7X10MM SHORT	28.5	Ø2.70	FUM 5010C	COUNTERSINK DRILL Ø4.8X10MM SHORT	28.5	Ø4.80

\* The kit is shipped with the cartridge and the component blister.

# UNITITE® GUIDED SURGERY KIT

## COMPLETE AND COMPACT KITS

Developed with high-tech innovation and superior industrial quality, S.I.N. Guided Surgery provides several benefits throughout the dental implant installation procedure.

Now you can offer your patients a more comfortable surgery, accurate precision, reduced surgical time and better postoperative recovery.

Discover what is the best in worldwide implantology.

Color coding modern and easy to browse through.



Options of installation in several diameters\*, lengths and prosthetic platforms of the implant lines.

Integrated Safe Drill system limiters that allow precise control of the alveolus depth.

CODE: KCSUG 04

With the S.I.N. Guided Surgery technique, you will have:

- Shorter surgery time, as there is greater precision in implant installation.
- More predictability and accuracy in planning.
- High implant survival rate.
- Reduced bleeding.
- Faster recovery for patient.
- Better postoperative recovery.
- Preservation of bone tissue volume around the implant.
- Better maintenance of soft tissue.
- Possibility of immediate installation of the prosthesis through a digital workflow.

### Long and short drill system

> Greater range of options according to the clinical case.

### Standard drills 42.5 mm

- > Millimetric depth markings;
- > Safe Drill fitting;
- > Recommended for all types of procedure.

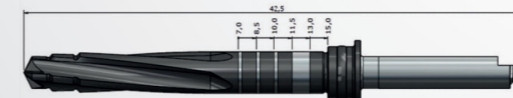

### Short Drills: 37.5 mm

- > Indicated for patients with poor mouth opening/posterior regions;
- > Allows the installation of implants of 7mm / 8.5mm / 10mm / 11.5mm\*\*;
- > It does not have a fitting for the Safe Drill limiter.

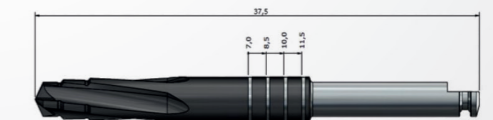

\*In condition H6.5 with short drill, the maximum implant length to be installed should be 10mm.

### Flexible sleeve positioning system

> It allows the PLACEMENT OF THE SURGICAL GUIDES IN TWO DIFFERENT POSITIONS in relation to the bone level.



### Narrow sleeve system

> It AVOIDS COLLISION BETWEEN GUIDE SLEEVES and orientation errors at short mesio-distal distances.



CODE	DESCRIPTION
AFG 14	SLEEVE FOR FIXER GUIDE Ø1.4MM
AG 40	SLEEVE FOR SURGICAL GUIDE Ø4.0MM
AG 50	SLEEVE FOR SURGICAL GUIDE Ø5.0MM

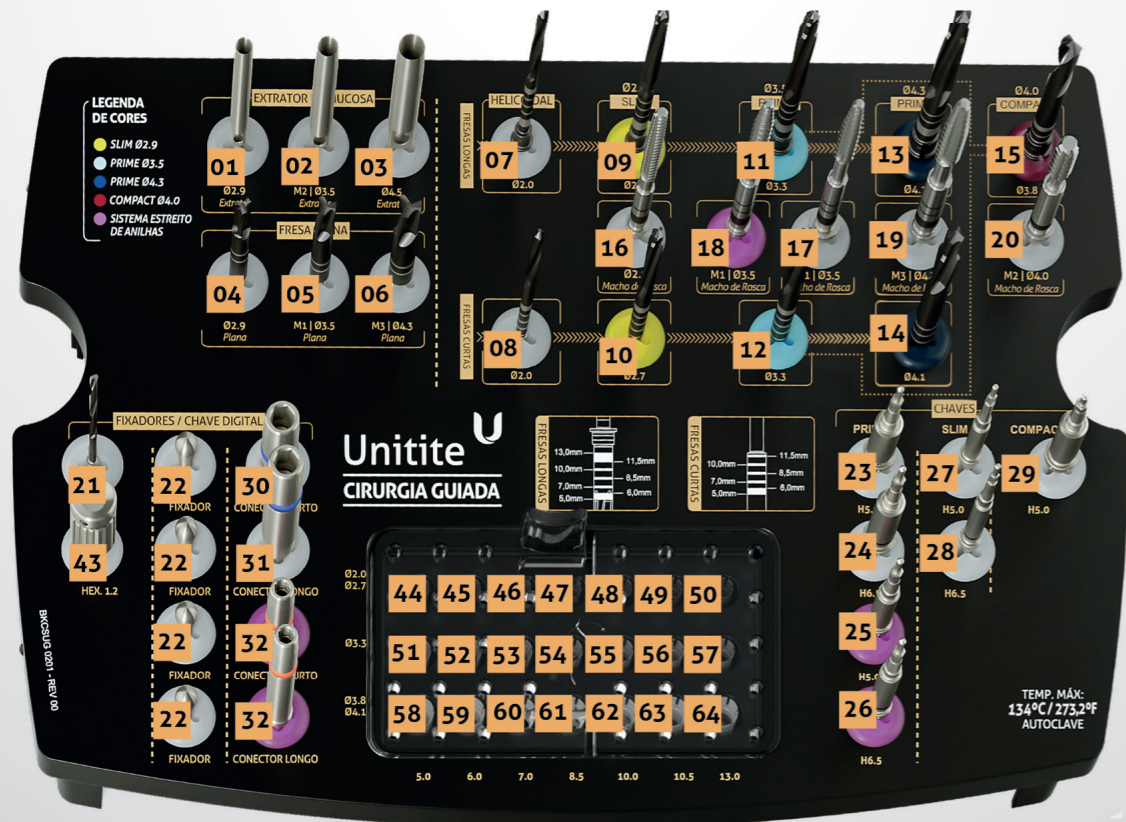
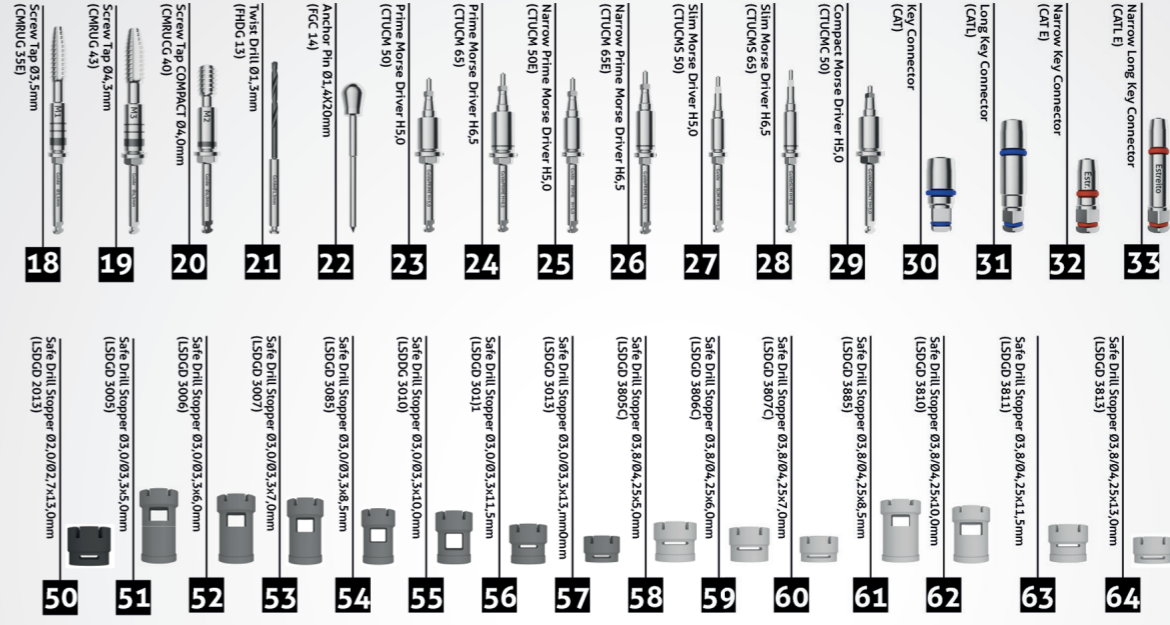
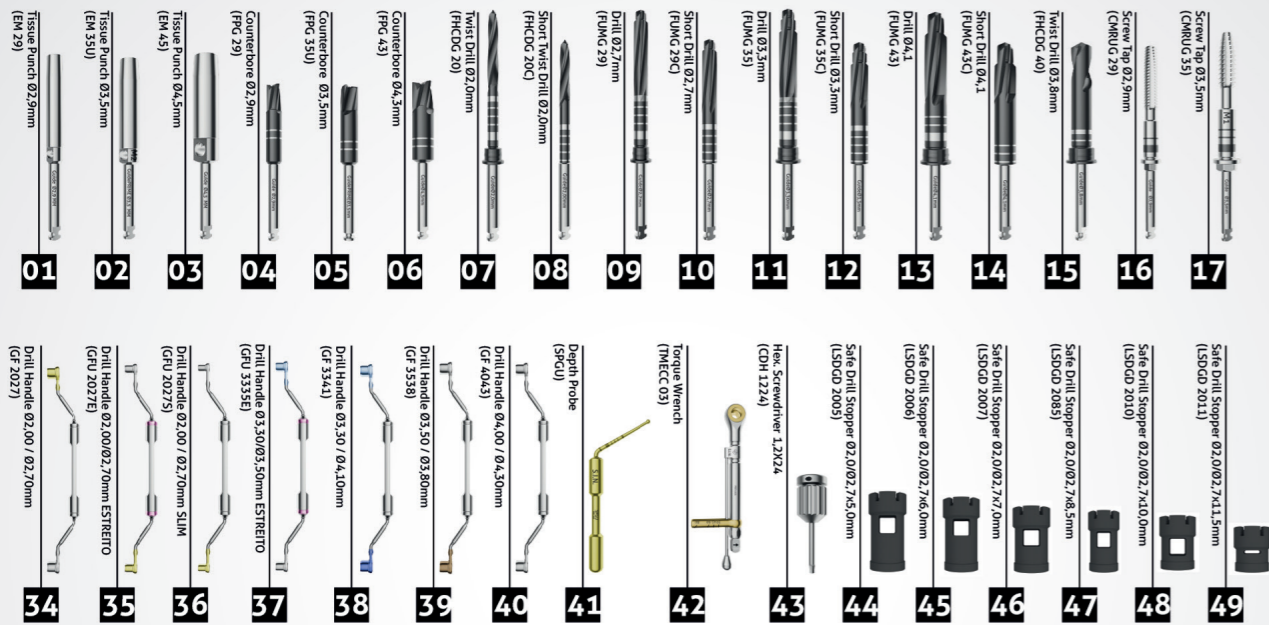

ORGANIZING BOX: COSUG 02

# GET TO KNOW OUR COMPLEMENTARY KITS



## PROSTHETIC KIT

Ideal for the restorative phase with precision, agility, and safety.

Code: KTMEC 02



## EXPANDER KIT

Ideal for performing lateral bone expansion, helping to avoid the need for bone grafts.

Code: KEXP



## BONE GRAFT KIT

Used for the stabilization of block bone grafts and for guided bone regeneration surgery.

Code: KENX



## SINUS LIFT KIT

Indicated for sinus lift surgeries, this kit enables displacement of the sinus membrane, as well as graft curettage and compaction.

Code: KLEV 02



## OSTEOTOME KIT

Enables atraumatic maxillary sinus elevation, resulting in vertical bone gain.

Code: KOST



## ROTARY EXPANDER KIT

Indicated for cases with limited bone thickness.

Recommended for bone expansion and compaction, helping to avoid the need for bone grafting.

Code: KER



## ORTHODONTIC KIT

Designed for simple surgical installation and removal of mini screws, assisting in orthodontic treatment.

Code: KOR



**WANT TO KNOW  
MORE? SCAN THE  
QR CODE NEXT TO IT**



# ORTHODONTIC IMPLANTS

- > Easy installation and removal.
- > Immediate loading can be done after surgical application.
- > Easy connection with orthodontic accessories.
- > Hole diameter : 0.6 mm.

## AUTO DRILLING APEX:

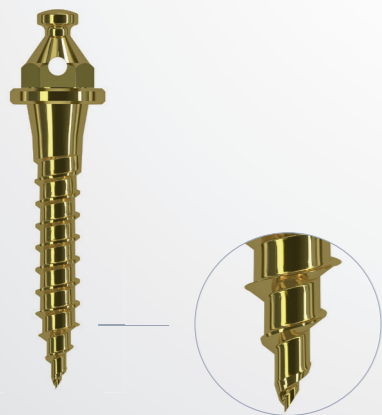

### INSTALLATION TECHNICAL INFORMATION

- › **Lengths:**  
Gingival depth = 0, 1, 2 and 3 mm.  
Length = 6, 8 and 10 mm. (6 and 8: lower jaw / 10: bone type IV).
- › **Diameter:**  
1.4 mm  
1.6 mm  
1.8 mm

### SELF-DRILLING WITHOUT TRANSMUCOSAL PROFILE



CODE	DIAM.	LENGTH
POT 1406	1.4 mm	6.0 mm
POT 1408	1.4 mm	8.0 mm
POT 1400	1.4 mm	10.0 mm
POT 1606	1.6 mm	6.0 mm
POT 1608	1.6 mm	8.0 mm
POT 1600	1.6 mm	10.0 mm
POT 1806	1.8 mm	6.0 mm
POT 1808	1.8 mm	8.0 mm
POT 1800	1.8 mm	10.0 mm

### SELF-DRILLING WITH TRANSMUCOSAL PROFILE (2MM)



CODE	DIAM.	LENGTH
POT 1420	1.4 mm	10.0 mm
POT 1428	1.4 mm	8.0 mm
POT 1620	1.6 mm	10.0 mm
POT 1628	1.6 mm	8.0 mm
POT 1820	1.8 mm	10.0 mm
POT 1828	1.8 mm	8.0 mm

### SELF-DRILLING WITH SHORT TRANSMUCOSAL PROFILE (1MM)



CODE	DIAM.	LENGTH
POT 1416	1.4 mm	6.0 mm
POT 1418	1.4 mm	8.0 mm
POT 1410	1.4 mm	10.0 mm
POT 1616	1.6 mm	6.0 mm
POT 1618	1.6 mm	8.0 mm
POT 1610	1.6 mm	10.0 mm
POT 1816	1.8 mm	6.0 mm
POT 1818	1.8 mm	8.0 mm
POT 1810	1.8 mm	10.0 mm

### SELF-DRILLING WITH TRANSMUCOSAL PROFILE (3MM)



CODE	DIAM.	LENGTH
POT 1438	1.4 mm	8.0 mm
POT 1430	1.4 mm	10.0 mm
POT 1638	1.6 mm	8.0 mm
POT 1630	1.6 mm	10.0 mm
POT 1838	1.8 mm	8.0 mm
POT 1830	1.8 mm	10.0 mm

## COMPLEMENTARY KITS INSTRUMENTAL

### DIGITAL DRIVERS

ITEM	CODE	DESCRIPTION	LENGTH	INDICATION
	CDA 20	ABUTMENT DRIVER 20,0MM	SHORT	Used to set the mini-abutment and conical abutment screw
	CDA 24	ABUTMENT DRIVER 24,0MM	LONG	Used to set the mini-abutment and conical abutment screw
	CDH 0920	HEXAGONAL DIGITAL DRIVER 20,0MM	SHORT	Used for installation of Externa Hex. Tryon implant cover, two-pieces straight universal abut and angled universal abut
	CDH 0924	HEXAGONAL DIGITAL DRIVER 24,0MM	LONG	Used for installation of Externa Hex. Tryon implant cover, two-pieces straight universal abut and angled universal abut
	CDH 1220	HEXAGONAL DIGITAL DRIVER 20,0MM	SHORT	Used to set the mounting piece, healing, transfer, retaining screw (PTL 16, PT 2006, PT 2008, PRH 20 and PRH 30) and lab screws. 1.2mm hexagonal tip
	CDH 1224	HEXAGONAL DIGITAL DRIVER 24,0MM	LONG	Used to set the mounting piece, healing, transfer, retaining screw (PTL 16, PT 2006, PT 2008, PRH 20 and PRH 30) and lab screws. 1.2mm hexagonal tip
	CDHA 1220	HEX. DIGITAL DRIVER 20,0MM ANG. MINI-ABUTMENT	SHORT	Used to set the angular mini-abutment screw 1.2mm hexagonal tip (except for the Unitite angular mini-abutment).
	CDHA 1224	HEX. DIGITAL DRIVER 24,0MM ANG. MINI-ABUTMENT	LONG	Used to set the angular mini-abutment screw 1.2mm hexagonal tip (except for the Unitite angular mini-abutment).
	CDHA 1237	HEX. DIGITAL DRIVER 37,0MM ANG. MINI-ABUTMENT	EXTRA LONG	Used to set the angular mini-abutment screw 1.2mm hexagonal tip (except for the Unitite angular mini-abutment).
	CDQ 1220	SQUARE DIGITAL DRIVER 20,0MM	SHORT	Used to set the square-fit retaining screws (PTQ 2008, PTQH 18 and PTQ 2006). 1.3mm tip

### SURGICAL HAMMER

ITEM	CODE	DESCRIPTION
	MART 1	> Surgical-grade stainless steel used with Osteotome and Expander kits. > Contact end made of synthetic material that provides improved sensitivity, less impact and reduced trauma during use











### DIGITAL DRIVERS

ITEM	CODE	DESCRIPTION	LENGTH.	INDICATION
	CDQ 1224	SQUARE DIGITAL DRIVER 24,0MM	LONG	Used to set the square-fit locking screws (PTQ 2008, PTQH 18 and PTQ 2006). 1.3mm tip
	CDQ 1237	SQUARE DIGITAL DRIVER 37,0MM	EXTRA LONG	Used to set the square-fit locking screws (PTQ 2008, PTQH 18 and PTQ 2006). 1.3mm tip
	CLH 1277	HEX. DRIVER 77,0MM	EXTRA LONG	Lab screwdriver. Used to set retaining screws (PTL 16, PT 2006, PT 2008, PRH 20 and PRH 30) and lab screws. 1.2mm hexagonal tip
	CLQ 1277	HEX. DRIVER 77,0MM	EXTRA LONG	Lab screwdriver. Used to set the square-fit retaining screws (PTQ 2008, PTQH 18 and PTQ 2006). 1.3mm tip
	CRC 16	PROVISIONAL CYLINDER REMOVAL DRIVER	SHORT	Used to remove 1.6mm 16° Morse Taper provisional cylinder
	CRC 18	PROVISIONAL CYLINDER REMOVAL DRIVER	SHORT	Used to remove the 1.8 mm 11.5° Morse Taper provisional cylinder
	CDH 1620	HEX DIGITAL DRIVER 1,6MM	SHORT	Used to remove the 1.8 mm 11.5° Morse Taper provisional cylinder
	CDH 1624	CHAVE DIGITAL HEX 1,6MM	MEDIUM	Used to set Multifunctional Abutment. 1.6mm Hex lid
	CCH 1620	RATCHET HEX DRIVER 1,6MM	SHORT	Used to set and torque of the Multifunction Abutment. 1.6mm Hex lid
	CCH 1624	RATCHET HEX DRIVER 1,6MM	MEDIUM	Used to set and torque of the Multifunction Abutment. 1.6mm Hex lid



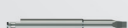

### BONE PROFILING MILLING CUTTERS

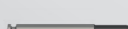
ITEM	CODE	DESCRIPTION	INDICATION
	PO 4150	Platform 4,1 mm - External Hex.	Open the bone profile to 5,0
	PO 5055	Platform 5,0 mm - External Hex.	Open the bone profile to 5,5
	POCM 45	Platform MT 11,5° - Morse Taper	Open the bone profile to 4,5
	POCM 50	Platform MT 11,5° - Morse Taper	Open the bone profile to 5,0
	POCM 55	Platform MT 11,5° - Morse Taper	Open the bone profile to 5,5
	POCM 65	Platform MT 11,5° - Morse Taper	Open the bone profile to 6,5
	POMT 45	Platform MT 16° - Morse Taper	Open the bone profile to 4,5
	POMT 50	Platform MT 16° - Morse Taper	Open the bone profile to 5,0
	POMT 55	Platform MT 16° - Morse Taper	Open the bone profile to 5,5
	POMT 65	Platform MT 16° - Morse Taper	Open the bone profile to 6,5





## COUNTER-ANGLE DRIVER

ITEM	CODE	DESCRIPTION	LENGTH	INDICATION
	CTA 1224	ABUTMENT TORQUE DRIVER 24.0MM	LONG	Used to set the mini-abutment and conical abutment screw.
	CTH 0924	COUNTER-ANGLE HEXAGONAL TORQUE DRIVER 24.0MM	LONG	Used for installation of Externa Hex. Tryon implant cover, two-pieces straight universal abut and angled universal abut.
	CTH 1220	COUNTER-ANGLE HEXAGONAL TORQUE DRIVER 20,0MM	SHORT	Used to set the mounting piece, healing, transfer, retaining screws (PTL 16, PT 2006, PT 2008, PRH 20 and PRH 30) and lab screws. 1.2mm hexagonal tip.
	CTH 1224	COUNTER-ANGLE HEXAGONAL TORQUE DRIVER 24.0MM	LONG	Used to set the mounting piece, healing, transfer, retaining screws (PTL 16, PT 2006, PT 2008, PRH 20 and PRH 30) and lab screws. 1.2mm hexagonal tip.
	CTH 1230	COUNTER-ANGLE HEXAGONAL TORQUE DRIVER 30,0MM	EXTRA LONG	Used to set the mounting piece, healing, transfer, retaining screws (PTL 16, PT 2006, PT 2008, PRH 20 and PRH 30) and lab screws. 1.2mm hexagonal tip.
	CTHA 1220	ANGULAR MINI-ABUTMENT COUNTER-ANGLE HEXAGONAL TORQUE DRIVER 20,0MM	SHORT	Used to set the angular mini-abutment screw 1.2mm hexagonal tip (except for the Unitite angular miniabutment).
	CTHA 1224	ANGULAR MINI-ABUTMENT COUNTER-ANGLE HEXAGONAL TORQUE DRIVER 24.0MM	LONG	Used to set the angular mini-abutment screw 1.2mm hexagonal tip (except for the Unitite angular miniabutment).
	CTQ 20	SQUARE TORQUE DRIVER 20,0MM	SHORT	Used counter-angle to set square-fit retaining screws (PTQ 2008, PTQH 18 and PTQ 2006). 1.3mm tip.
	CTQ 24	SQUARE TORQUE DRIVER 24.0MM	LONG	Used counter-angle to set square-fit retaining screws (PTQ 2008, PTQH 18 and PTQ 2006). 1.3mm tip
	CTQ 30	SQUARE TORQUE DRIVER 30,0MM	EXTRA LONG	Used counter-angle to set square-fit retaining screws (PTQ 2008, PTQH 18 and PTQ 2006). 1.3mm tip.
	CTH 1620	COUNTER-ANGLE HEX DRIVER 1.6MM	SHORT	Used in contra-angle to set Multifunction Abutment.
	CTH 1624	COUNTER-ANGLE HEX DRIVER 1.6MM	MEDIUM	Used in contra-angle to set Multifunction Abutment.

## HELICAL MILLING CUTTERS

ITEM	CODE	MEASUREMENTS	DESCRIPTION
	FH 2010	ø 2.0x 10,0 mm	> Surgical-grade stainless steel > Thermal treatment > Laser markings > Used as a sequence to make the alveolus
	FH2020	ø 2.0x 18,0 mm	
	FH3010	ø 3.0x 10,0 mm	
	FH3020	ø 3.0x 18,0 mm	

## TREPINE MILLING

ITEM	CODE	MEASUREMENTS	DESCRIPTION
	FTR 02	ø 2.0 mm	> Surgical-grade stainless steel > Thermal treatment > Laser markings > May be used to remove implants, remove bone, and bone biopsy > Measures refer to the inner diameter of the part
	FTR04	ø 4,2 mm	
	FTR 05	ø 5,1 mm	
	FTR 06	ø 6,1 mm	
	FTR 08	ø 8,0 mm	

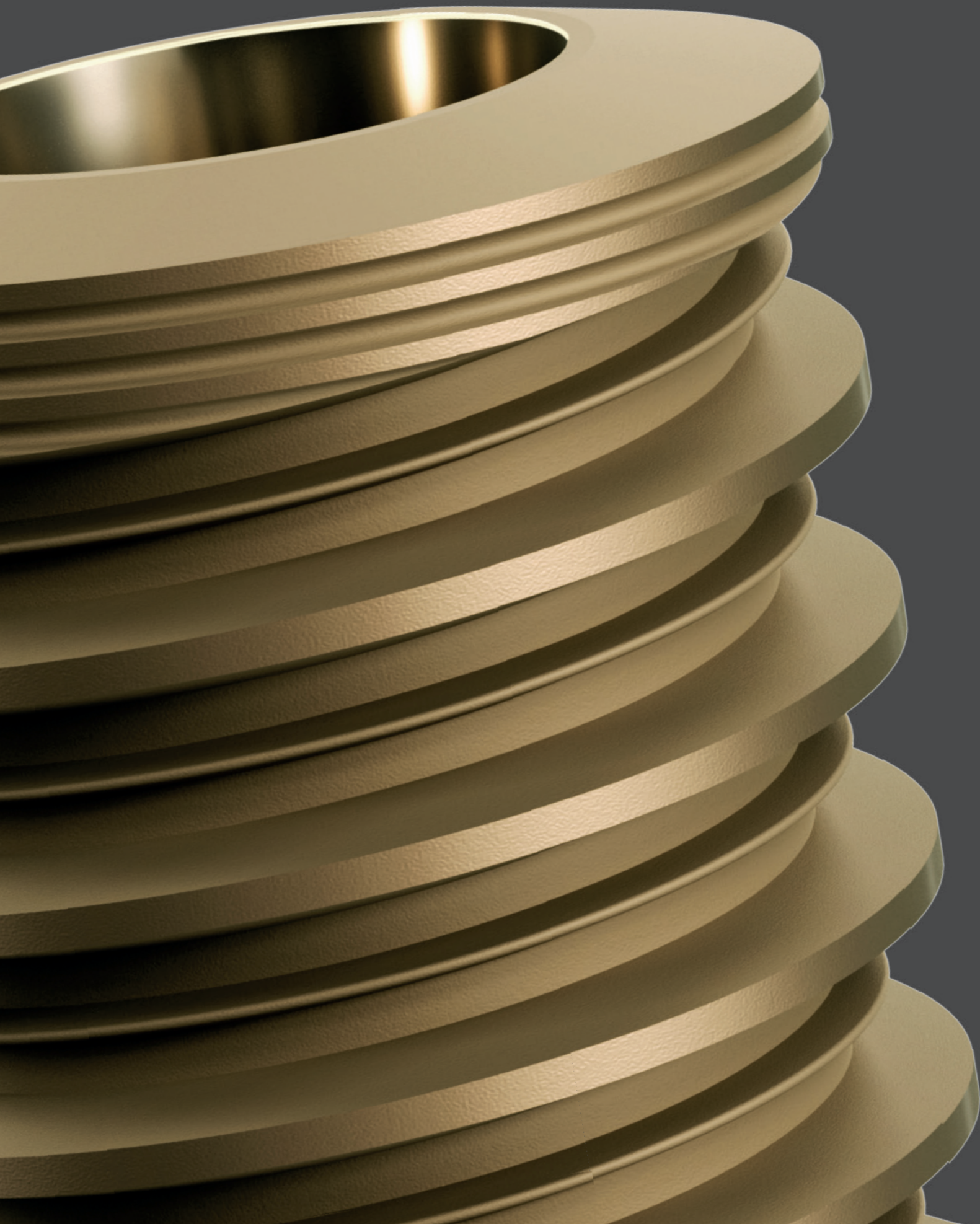

# SUPERIOR QUALITY AND TECHNOLOGY

*WE WARRANT, BECAUSE WE ARE PROUD  
OF OUR PRODUCTS.*

S.I.N.'s main priority is assuring the quality and safety to our clients. Offering the best for implants, components, surgical kits and tooling is the base of all our action.

## INSPECTION IN A 100% OF THE BATCHES MANUFACTURED.

The quality control is made in all S.I.N. products, to assure the success in the surgeries of all our clients, to meet the best quality standards, as well as to add value to all the ones who chose to give a smile back to people.



**IMPLANTS WITH WARRANTY  
FOR LIFE\***



**5 YEARS OF WARRANTY  
PROSTHESIS COMPONENTS\***



\*SCAN THE LATERAL QR CODE TO ACCESS  
S.I.N WARRANTY TERMS OR ACCESS THE LINK  
[WWW.SINIMPLANTSYSTEM.COM/LIFETIME-WARRANTY/](http://WWW.SINIMPLANTSYSTEM.COM/LIFETIME-WARRANTY/)



# S.I.N. ORIGINAL COMPONENTS

S.I.N. ensures the quality of your implants and original components. Our manufacturing process has strict quality control and safety, approved by various national and international certifications.

Learn about the advantages of using implants and original components S.I.N.:

- › The compatibility of the components tested in mechanical studies.
- › Production of the components corresponds exactly to the internal designs of the implant.
- › Accurate fit prevents bone loss and loosening or screw fracture.
- › Guarantee the use of high quality raw material.
- › Mechanical resistance to occlusion forces.
- › Greater safety by providing quality products to yours patients.
- › The pink color of Unitite® components makes the appearance of the prosthesis in the transmucosus much more natural even when there is retraction, salcerization or peri-implant changes.



## MORE EASE AND SAFETY FOR YOUR CLINICAL PROCEDURES

*S.I.N. packaging are practical, maintaining the products in their integrity, facilitating the handling and the identification.*

- › **01** The package is easy to open and handle even with gloves on.

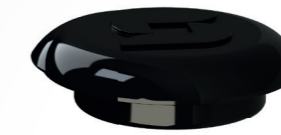

- › **02** Transparency of package for optimal visibility of the implant.



- › **03** Separate compartments in same package for implant and cover.

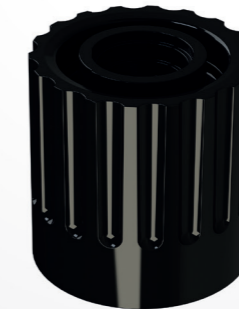

- › **04** Snap-on top opening system ensures sterilization of the implant.

- › **05** With a proper connector, capture the implant with the counter angle key and move it until it reaches the perfect fit.



- › **06** The only implant system that offers the cover screw in the same packaging. To capture it, remove the cover screw of the tube with in the 1.2 mm hexagonal digital key.

**The implant should not be captured with the ratchet wrench.**

# GENERAL INSTRUCTIONS

Special care and clarification on surgical instruments.



## CLEANING THE KIT CASE

1. Manually remove all surgical instruments from the kit. Wash the kit trays separately.
2. Prepare the enzymatic detergent according to the detergent manufacturer's recommendation.
3. Immerse all parts of the product into the prepared detergent solution and leave for 5 minutes. Then, using a soft bristle brush, scrub the parts for at least 2 minutes until complete remove organic matter from the products.
4. Remove the parts from the detergent solution and rinse with tap water for 1 minute until the residue is completely removed. Repeat the rinse two more times.
5. Visually inspect each part to check for process residues or organic residues from the used of the product.
6. If residue in detect in the product, repeat the cleaning process until the residue is completely removed.
7. Dry with a soft, clean, dry cloth or disposable paper.



## STERILIZATION

Product reusable and provided non-sterile. It must be clean and sterilized in autoclave before use.

Dry all instruments before the steam sterilization cycle.

The product is to be enclosed in a steam sterilizable wrap.

Steam sterilize in cycles from 121°C to 1 ATM pressure for 30 minutes or from 134°C to 2 ATM pressure for 20 minutes. Drying time 30 minutes

Always accommodate the case in autoclave over a plane surface and away of device walls.

Never stack objects or other cases.



## CLEANING THE SURGICAL INSTRUMENTS

1. Prepare the enzymatic detergent according to the detergent manufacturer's recommendation.
2. Immerse all parts of the product into the prepared detergent solution and leave for 5 minutes. Then, using a soft bristle brush, scrub the parts for at least 2 minutes until complete remove organic matter from the products.
3. Remove the parts from the detergent solution and rinse with tap water for 1 minute until the residue is completely removed. Repeat the rinse two more times.
4. Visually inspect each part to check for process residues or organic residues from the used of the product.
5. If residue in detect in the product, repeat the cleaning process until the residue is completely removed.
6. Dry with a soft, clean, dry cloth or disposable paper.
7. Proceed to the sterilization process.

## CLEANING OF TORQUE RATCHET

1. Pull the steering reversing rod back.
2. Remove the ratchet from the socket with your head.
3. Rotate the fixing door counterclockwise.
4. Remove the central shaft of the Torque Ratchet.
5. Remove the torque grading rod.
6. Prepare the enzymatic detergent according to the manufacturer's instructions.
7. Immerse all parts of the product in the prepared detergent solution and leave for at least 5 minutes, then using a soft bristle brush, scrub the parts to remove organic matter from the products.
8. Remove the pieces from the detergent solution and rinse with running water for 1 minute, repeat the rinse two more times, totaling 3 rinses of 1 minute each.
9. Visually inspect each piece to check whether there is residue from the cleaning process or organic residues from the use of the product.
10. If the presence of residue on the product is confirmed, repeat the cleaning process until the residue is completely removed.
11. Dry with a soft, clean, dry cloth or disposable paper.

## CLEANING RECOMMENDATION

- a. Wear appropriate clothing (gloves, masks, glasses, hats, etc.).
- b. Begin cleaning immediately after surgical use.
- c. Never let the instrument dry containing organic residues after surgical use.
- d. Never let the instrument dry naturally after cleaning.
- e. Never use saline solutions, especially sodium hypochlorite and saline, disinfectants, hydrogen peroxide or alcohol to clean or rinse surgical instruments and Kit trays.
- f. Never use steel wool or sponges or abrasive products, so that the instruments are not damaged.
- g. Do not accumulate instruments in large quantities on top of each other to avoid deformation of smaller and delicate pieces.

## STERILIZATION RECOMMENDATIONS

- Sterilize the products in the same day or one day earlier the procedure.
- The chemical sterilization is not recommend, once some products may cause the discoloration and damages to the case.
- Do not use temperature higher than 60°C to drying process.
- Do not use dry heat stoves for sterilization of the instruments and S.I.N kits.

STERILIZATION TEMPERATURE	AUTOCLAVE PRESSURE	AUTOCLAVE TIME	NOTE:
TO BE USED	TO BE SET TO	TO BE SET TO	IMPORTANT
121°C	1 ATM (**)	30 Minutes (**)	(*) Always check the water level of your autoclave before starting the cycle.
134°C	2 ATM (**)	20 Minutes (**)	

(\*) It is mandatory to use water in the autoclaves.  
 (\*\*) We are not held responsible if parameters other than those specified above are used.  
 (\*\*\*) Do not sterilize by dry heat.

# TORQUE RATCHET CLEANING PROCEDURES

The ratchet must be disassembled and cleaned immediately after every use.

For proper cleaning, disassemble multi-piece instruments into their single parts. No tools are necessary for this process.



# WHAT THE SPECIALISTS SAY

“

UNITITE IMPLANTS HAVE MADE THE RESULTS OF CURRENT MAJOR CLINICAL DEMANDS MORE PREDICTABLE, SUCH AS SHORTENING THE TIME BETWEEN IMPLANT INSTALLATION AND FINAL PATIENT REHABILITATION, MAINTAINING PERI-IMPLANT BONE HEIGHT, WHICH HAS A LARGE IMPACT ON LONG-TERM AESTHETIC PREDICTABILITY AND THE REHABILITATION OF AREAS WITH POOR BONE AVAILABILITY IN AN EFFICIENT AND MINIMALLY INVASIVE WAY, IN MANY CASES AVOIDING THE NEED FOR BONE GRAFTS. I AM VERY FLATTERED TO HAVE PARTICIPATED ACTIVELY IN THIS PROJECT. ”

Researcher in the Bme - KULeuven, Belgium. Post-PhD in Biomechanics by the FEMEC/UFU and Researcher in the Bme KULeuven, Belgium. PhD in Periodontics/Dental Implant - FOAr/UNESP - Araraquara, Brazil. Master in Oral Rehabilitation - FOUFU - Uberlândia, Brazil.



Roberto Pessoa

“

SURFACE COATING HANANO®, USED IN THE UNITITE IMPLANT, AND 20 NANOMETERS THICK, HOMOGENEOUSLY COATING THE ENTIRE SURFACE, SIGNIFICANTLY INCREASES SURFACE ENERGY, HYDROPHILICITY AND SCAR RESPONSE IN THE EARLY STAGES OF THE OSSEOINTEGRATION PROCESS. THE POSITIVE IMPACT OF ITS BIOAVAILABILITY HAS BEEN DEMONSTRATED BY DIFFERENT ADVANCED METHODS OF RESEARCH, SUCH AS SIGNAL TRANSDUCTION AND ATOMIC FORCE MICROSCOPY. HIGHER PROTEIN ADSORPTION, ASSOCIATED TO A STATISTICALLY SIGNIFICANT PRESENCE OF PROTEINS RELATED TO THE BONE HEALING PROCESS IN THE PRESENCE OF A BIOLOGICAL CATALYST FOR MINERALIZATION, MAKE THIS SURFACE ONE OF THE MOST ADVANCED IN THE IMPLANTS GLOBAL MARKET. ”

A Graduate of Bauru School of Dentistry - USP  
Specialist in Periodontics, Bauru School of Dentistry - USP  
Specialist in Implantology by INEPO - SP  
Master in Implantology by UNIP - São Paulo  
Doctor in Biotechnology by IBB - UNESP



Fabio Bezerra



Ann Wennerberg

“ OUR RESEARCH GROUP HAS WORKED WITH THE HANANO® SURFACE FOR OVER 10 YEARS. UNTIL NOW THIS RESEARCH HAS RESULTED IN TWO DOCTORAL THESES AND ANOTHER ONE IS IN PROGRESS. OUR EXPERIMENTAL RESULTS IN 17 IN VIVO STUDIES, MOSTLY ON RABBITS, USUALLY SHOWS AN IMPROVED BONE RESPONSE FOR THE TITANIUM WITH THE HANANO® SURFACE AND PEEK IMPLANTS WHEN COMPARED WITH IMPLANTS WITHOUT THIS SURFACE. ”

DDS/PhD and Director of the Department of Dental Prosthesis at the Malmö University, Sweden. Specialized in Implant Surface and author of more than 220 scientific articles published in renowned magazines on this subject.

“

WITH THE NEW SURFACE OF UNITITE, WE HAVE NOTICED THROUGH STUDIES THAT PRIMARY STABILITY IS ACTUALLY OBTAINED. THE MACROGEOMETRY OF THE IMPLANT ITSELF ALLOWS THE BLOOD TO FLOW THROUGH THE ENTIRE IMPLANT, AND THERE IS A COMPLETE OSSEOINTEGRATION FROM THE APEX OF THE IMPLANT TO THE CENTRAL WALLS, AND EVEN TO THE CERVICAL AREA OF THE IMPLANT ITSELF. THE UNITITE IS, WITHOUT A DOUBT, A MAJOR STEP FORWARD IN THE WORLD OF IMPLANTOLOGY, NOT ONLY ACCORDING TO THE MULTICENTER STUDIES, BUT ALSO THE RESULTS AND THE RADIOGRAPHIC AND CLINICAL CONTROLS THAT WE HAVE, WHICH ARE VERY ENCOURAGING. ”

PhD and Masters in Oral and Maxillofacial Surgery at the Eastman Dental Institute – University of London – and Professor at the Instituto Superior de Saúde do Alto Ave (ISAVE) in Portugal.



Fernando Duarte



Per Kjellin

“ THE HANANO® SURFACE IS AN ULTRATHIN LAYER OF SYNTHETIC BONE ON THE SURFACE OF THE IMPLANT. EACH CRYSTAL OF SYNTHETIC BONE IS EXTREMELY SMALL, 10 TO 14 NM IN LENGTH AND ABOUT 5NM IN THICKNESS. WHAT MAKES THESE CRYSTALS SO SPECIAL IS THAT THEY HAVE THE SAME SIZE AND SHAPE AS THOSE FOUND IN HUMAN BONE AND ARE RECOGNIZED BY THE BONE CELLS, AS WELL AS BY THE BONE TISSUE, WHICH ACTIVATES THE CATALYZER AND STARTS A HUGE PROCESS OF BUILDING BONE AROUND THE IMPLANT. THIS EFFECT HAS BEEN PROVEN IN MORE THAN 20 PRE-CLINICAL STUDIES WITH THE BEST RESEARCHERS IN THE WORLD IN THE AREA OF IMPLANTS. ”

CTO of Promimic, Co-inventor of the HANano® surface, PhD in Materials and Chemical Surfaces by the Chalmers University in Gothenburg, Sweden, and author of several studies in the area of nanomaterials.

# SCIENTIFIC PUBLICATIONS

Arvidsson A, Currie F, Kjellin P, Sul YT, Stenport V. Nucleation and growth of calcium phosphates in the presence of fibrinogen on titanium implants with four potentially bioactive surface preparations. An in vitro study. *J Mater Sci: Mater Med* 2009; 20:1869–1879

Arvidsson A, Franke-Stenport V, Andersson M, Kjellin P, Sul YT, Wennerberg A. Formation of calcium phosphates on titanium implants with four different bioactive surface preparations. An in vitro study. *J Mater Sci: Mater Med* 2007; 18:1945-1954

Barkarmo S, Wennerberg A, Hoffman M, Kjellin P, Breeding K, Handa P, Stenport V. 2013. Nanohydroxyapatite-coated PEEK implants: A pilot study in rabbit bone. *J Biomed Mater Res A* 2013; 101A:465–471

Bezerra F, Pessoa RS, Zambuzzi WF. Carregamento funcional imediato ou precoce de implants com câmara de cicatrização e nano-superfície: estudo clínico prospectivo longitudinal. *Innov Implant J, Biomater Esthet.* 2015;9(2/3):13-7

Bezerra F, Lenharo A, Pessoa RS, Duarte LRS, Granjeiro JM. Avaliação do impacto do edentulismo total mandibular e da reabilitação fixa sobre implants com carga imediata na qualidade de vida de pacientes idosos. *Rev Dental Press Periodontia Implantol.* 2011 jul-set;5(3):101-10

Bezerra F, Ribeiro EDP, Bittencourt S, Lenharo A. Influência da experiência do operador na estabilidade primária de implants com diferentes macro-geometrias – estudo in vitro. *Int J Dent* 2010; 9(2):63-67

Bezerra F, Ribeiro EP, Bittencourt S, Lenharo A. Influência da macrogeometria na estabilidade primária dos implants em diferentes densidades ósseas. *Implant News* 2010;7(5):671-6.

Bezerra F, Ribeiro EP, Bittencourt S, Lenharo A. Influência da macrogeometria na estabilidade dos implants. *Innov Implant J* 2010; 5:29-34

Bonfante EA, Janal MN, Granato R, Marin C, Suzuki M, Tovar N, Coelho PG. Buccal and lingual bone level alterations after immediate implantation of four implant surfaces: a study in dogs. *Clin. Oral Impl. Res.* 2013; 24:1375–1380

Bonfante EA, Granato R, Marin C, Suzuki M, Oliveira SR, Giro G, Coelho PG: Early bone healing and biomechanical fixation of dual acid-etched and as-machined implants with healing chambers: an experimental study in dogs. *The International Journal of Oral & Maxillofacial Implants* 2011; 26: 75-82

Campos FEB, Jimbo R, Bonfante EA, Barbosa EA, Oliveira MTF, Janal MN, Coelho PG. Are insertion torque and early osseointegration proportional? A histologic evaluation. *Clinical Oral Implants Research* 2014 Jul 4. doi: 10.1111/clr.12448. [Epub ahead of print]

Campos FEB, Jimbo R, Bonfante EA, Oliveira MTF, Moura C, Barbosa DZ, Coelho PG. Drilling dimension effects in early stages

of osseointegration and implant stability in a canine model. *Med Oral Patol Oral Cir Bucal.* 2015 Apr 10. [Epub ahead of print]

Arvidsson A, Currie F, Kjellin P, Sul YT, Stenport V. Nucleation and growth of calcium phosphates in the presence of fibrinogen on titanium implants with four potentially bioactive surface preparations. An in vitro study. *J Mater Sci: Mater Med* 2009; 20:1869–1879

Arvidsson A, Franke-Stenport V, Andersson M, Kjellin P, Sul YT, Wennerberg A. Formation of calcium phosphates on titanium implants with four different bioactive surface preparations. An in vitro study. *J Mater Sci: Mater Med* 2007; 18:1945-1954

Barkarmo S, Wennerberg A, Hoffman M, Kjellin P, Breeding K, Handa P, Stenport V. 2013. Nanohydroxyapatite-coated PEEK implants: A pilot study in rabbit bone. *J Biomed Mater Res A* 2013; 101A:465–471

Bezerra F, Pessoa RS, Zambuzzi WF. Carregamento funcional imediato ou precoce de implants com câmara de cicatrização e nano-superfície: estudo clínico prospectivo longitudinal. *Innov Implant J, Biomater Esthet.* 2015;9(2/3):13-7

Bezerra F, Lenharo A, Pessoa RS, Duarte LRS, Granjeiro JM. Avaliação do impacto do edentulismo total mandibular e da reabilitação fixa sobre implants com carga imediata na qualidade de vida de pacientes idosos. *Rev Dental Press Periodontia Implantol.* 2011 jul-set;5(3):101-10

Bezerra F, Ribeiro EDP, Bittencourt S, Lenharo A. Influência da experiência do operador na estabilidade primária de implants com diferentes macro-geometrias – estudo in vitro. *Int J Dent* 2010; 9(2):63-67

Bezerra F, Ribeiro EP, Bittencourt S, Lenharo A. Influência da macrogeometria na estabilidade primária dos implants em diferentes densidades ósseas. *Implant News* 2010;7(5):671-6.

Bezerra F, Ribeiro EP, Bittencourt S, Lenharo A. Influência da macrogeometria na estabilidade dos implants. *Innov Implant J* 2010; 5:29-34

Bonfante EA, Janal MN, Granato R, Marin C, Suzuki M, Tovar N, Coelho PG. Buccal and lingual bone level alterations after immediate implantation of four implant surfaces: a study in dogs. *Clin. Oral Impl. Res.* 2013; 24:1375–1380

Bonfante EA, Granato R, Marin C, Suzuki M, Oliveira SR, Giro G, Coelho PG: Early bone healing and biomechanical fixation of dual acid-etched and as-machined implants with healing chambers: an experimental study in dogs. *The International Journal of Oral & Maxillofacial Implants* 2011; 26: 75-82

Campos FEB, Jimbo R, Bonfante EA, Barbosa EA, Oliveira MTF, Janal MN, Coelho PG. Are insertion torque and early osseointegration proportional? A histologic evaluation. *Clinical Oral Implants Research* 2014 Jul 4. doi: 10.1111/clr.12448. [Epub ahead of print]

Campos FEB, Jimbo R, Bonfante EA, Oliveira MTF, Moura C, Barbosa DZ, Coelho PG. Drilling dimension effects in early stages of osseointegration and implant stability in a canine model. *Med Oral Patol Oral Cir Bucal.* 2015 Apr 10. [Epub ahead of print]

Coelho PG, Marin C, Granato R, Bonfante EA, Lima CP, Oliveira S, Ehrenfest DMD, Suzuki M. Alveolar Buccal Bone Maintenance After Immediate Implantation with a Surgical Flap Approach: A Study in Dogs. *The International Journal of Periodontics & Restorative Dentistry* 2011;31:e80–e86

Coelho PG, Granjeiro JM, Romanos GE, Suzuki M, Silva NR, Cardaropoli G, et al. Basic research methods and current trends of dental implant surfaces. *J Biomed Mater Res B Appl Biomater.* 2009;88(2):579-96.

Coelho PG, Jimbo R. Osseointegration of metallic devices: current trends based on implant hardware design. *Archives of biochemistry and biophysics.* 2014;561:99-108

Coelho PG, Jimbo R, Tovar N, Bonfante EA. Osseointegration: hierarchical designing encompassing the micrometer, micrometer, and nanometer length scales. *Dent Mater.* 2015;31(1):37-52

Ehrenfest DMD, Coelho PG, Kang BS, Sul YT, Albrektsson T. Classification of osseointegrated implant surfaces: materials, chemistry and topography. *Trends in Biotechnology* 2009; 198-206

Jimbo R, Coelho PG, Bryington M, Baldassarri M, Tovar N, Currie F, et al. Nano hydroxyapatite-coated implants improve bone nanomechanical properties. *J Dent Res.* 2012;91(12):1172-7.

Jimbo R, Coelho PG, Bryington M, Baldassarri M, Tovar N, Currie F, et al. Nano hydroxyapatite-coated implants improve bone nanomechanical properties. *J Dent Res.* 2012;91(12):1172-7

Jimbo R, Sotres J, Johansson C, Breeding K, Currie F, Wennerberg A. The biological response to three different nanostructures applied on smooth implant surfaces. *Clin Oral Implants Res.* 2012;23(6):706-12.

Martins LM, Bonfante EA, Zavanelli RA, Freitas Jr AC, Silva NRFA, Marotta L, et al. Fatigue reliability of three single-unit implant-abutment designs. *Implant Dent.* 2011; 21: 67-71

Meirelles L, Albrektsson T, Kjellin P, Arvidsson A, Franke-Stenport V, Andersson M, Currie F, Wennerberg A. Bone reaction to nano hydroxyapatite modified titanium implants placed in a gap-healing model. *Journal of Biomedical Materials Research A* 2008; 625-631

Meirelles L, Albrektsson T, Kjellin P, Arvidsson A, Franke-Stenport V, Andersson M, Currie F, Wennerberg A. Bone reaction to nano hydroxyapatite modified titanium implants placed in a gap-healing model. *Journal of Biomedical Materials Research A* 2008; 625-631

Meirelles L, Arvidsson A, Andersson M, Jellin P, Albrektsson T, Wennerberg A: Nano hydroxyapatite structures influence early bone formation. *J Biomed Mater Res A.* 2008 Nov;87(2):299-307

Meirelles L, Currie F, Jacobsson M, Albrektsson T, Wennerberg A. The effect of chemical and nanotopographical modifications on the early stages of osseointegration. *Int J Oral Maxillofac Implants* 2008;23: 641-647

Meirelles L, Melin L, Peltola T, Kjellin P, Kangasniemi I, Currie

F, Andersson M, Albrektsson T, Wennerberg A. Effect of Hydroxyapatite and Titania Nanostructures on Early In Vivo Bone Response. *Clinical Implant Dentistry and Related Research* 2008; 10(4): 245-254

Meirelles L, Melin L, Peltola T, Kjellin P, Kangasniemi I, Currie F, Andersson M, Albrektsson T, Wennerberg A. Effect of Hydroxyapatite and Titania Nanostructures on Early In Vivo Bone Response. *Clinical Implant Dentistry and Related Research* 2008; 10(4): 245-254

Pessoa RS, Coelho PG, Muraru L, Marcantonio Jr E, Vaz LG, Sloten JV, Jaecques SVN: Influence of implant design on the biomechanical environment of immediately placed implants: computed tomography-based nonlinear three-dimensional finite element analysis. *Int J Oral Maxillofac Implants* 2011;26:1279–1287

Pessoa RS, Souza RM, Pereira LM, Neves FD, Jaecques SVN, Sloten JV, Quirynen M, Teughels W, Spin-Neto R. Remodelação óssea de implants com conexão hexágono externo e elementos de retenção no módulo da crista sob carregamento imediato – estudo clínico prospectivo longitudinal de um ano. *ImplantNews* 2015;12(4):E2-E7

Pessoa RS, Sousa RM, Pereira LM, Silva TD, Bezerra FJB, Spin-Neto R. Avaliação da estabilidade dos tecidos duros e moles em implants imediatos com carga imediata em área estética: estudo clínico. *Dental Press Implantol.* 2015 Apr-Jun;9(2):100-9

Lenharo A, Granjeiro JM, Leão L, Bezerra F, Oliva MA. Estudo prospectivo longitudinal multicêntrico avaliando o sucesso clínico de uma nova macrogeometria de implants osseointegráveis: acompanhamento de 06 a 12 meses. *Revista Fluminense de Odontologia* 2010; 34: 43-48

Göransson A, Arvidsson A, Currie F, Franke-Stenport V, Kjellin P, Mustafa K, Sul YT, Wennerberg A. An in vitro comparison of possibly bioactive titanium implant surfaces. *Journal of Biomedical Materials Research A* 2008; 1037-1047

Shunmugasamy VC, Gupta N, Pessoa RS, Janal MN, Coelho PG. Influence of clinically relevant factors on the immediate biomechanical surrounding for a series of dental implant designs. *J Biomech Eng.* 2011;133(3):031005.

Svanborg LM, Meirelles L, Franke-Stenport V, Kjellin P, Currie F, Andersson M, Wennerberg A. Evaluation of Bone Healing on Sandblasted and Acid Etched Implants Coated with nanocrystalline Hydroxyapatite: An In Vivo Study in Rabbit Femur. *International Journal of Dentistry* 2014; 1-7

Westas E, Gillstedt M, Lönn-Stensrud J, Bruzell E, Andersson M: Biofilm formation on nanostructured hydroxyapatite-coated titanium. *J Biomed Mater Res A.* 2014 Apr;102(4):1063-70

## OUR GLOBAL PRESENCE



POINT YOUR PHONE'S CAMERA AT THE  
QR CODE AND SEE WHERE S.I.N. IS PRESENT

**[sinimplantsystem.com](http://sinimplantsystem.com)**

CNPJ: 04.298.106/0001-74

SAC: 0800 770 8290

[sin@sinimplantsystem.com](mailto:sin@sinimplantsystem.com)



Get to know Implantat, the educational streaming of S.I.N.

 [implantat.global](https://www.implantat.global)

[internacional@sinimplantsystem.com](mailto:internacional@sinimplantsystem.com)  
[www.sinimplantsystem.com](https://www.sinimplantsystem.com)

---

Visit our social networks



[@sin.global](https://www.instagram.com/sin.global)



[@sin.global](https://www.facebook.com/sin.global)



[S.I.N. Implant System](https://www.youtube.com/S.I.N.ImplantSystem)



[/sin\\_implant](https://www.tiktok.com/sin_implant)